



LOGIC ANALYZER

LAP-C

USER GUIDE

Version: V3.14.02



Table of Content

Table of Content	2
Table of Figures	8
Table of Tables	12
Precautions	14
1. Introduction	15
1.1. Preface	15
1.2. About this Document	16
1.3. Product Introduction	16
1.4. Package Content.....	16
1.5. System Requirements	17
1.5.1. Operating System Support	17
1.5.2. Hardware Requirements	18
1.6. Product Specifications	18
1.6.1. Product Photos.....	18
1.6.2. Specifications	19
1.6.3. Available Models	22
1.6.4. Optional Functions	22
1.6.5. Electrical Specifications	22
1.6.6. Pin Overview	23
2. Installation and Setup	25
2.1. Software Installation	25
2.2. Hardware Connections.....	26
2.3. Trigger IN/OUT	27
2.3.1. Trigger IN.....	27
2.3.2. Trigger OUT.....	27



2.4. Operating Environment and Maintenance	27
3. User Interface	29
3.1.1. Main Window.....	29
3.1.2. Right-click Menus.....	31
4. Software Operations	37
File	37
4.1. Menu layout	37
4.2. New.....	37
4.3. Open.....	37
4.4. Close.....	38
4.5. Save.....	38
4.6. Save As.....	38
4.7. Auto Save	39
4.8. Screen Capture	39
4.9. Export	40
4.9.1. Packet List.....	40
4.9.2. Waveform	42
4.10. Print	44
4.11. Print Preview.....	45
4.12. Settings.....	45
4.12.1. General.....	46
4.12.2. Options.....	47
4.12.3. Toolbars.....	49
4.12.4. Colors Settings.....	50
4.12.5. Shortcut Key.....	51
4.12.6. Auto Save.....	52
4.13. Recent files.....	53
4.14. Exit.....	53
Acquisition	53
4.15. Menu Layout.....	53



4.16. Group into Bus.....	53
4.17. Ungroup from Bus	54
4.18. Bus Properties (Protocol decoders)	54
4.19. Channel Assignment	57
4.20. Acquisition Setup	59
4.21. Signal Filter Setup	62
4.22. Trigger Setup – Channel	65
4.23. Trigger Setup – Bus.....	66
4.24. Trigger Properties	69
4.24.1. Trigger Settings	69
4.24.2. Trigger Count	71
4.24.3. Trigger Delay	71
4.24.4. Trigger Position	72
4.24.5. Repeated Triggering	73
4.25. Pulse Width Trigger Module	74
4.26. Connect Multiple LAP-Cs	74
4.27. Connect to DSO	76
4.27.1. LAP-C as Master.....	77
4.27.2. LAP-C as Slave.....	77
4.27.3. Settings	78
4.27.4. Result	80
4.27.5. Supported DSO models	81
4.28. Single Capture.....	82
4.29. Repeated Run	82
4.30. Stop.....	82
4.31. Cumulative Packet Run.....	83
Analysis.....	84
4.32. Menu Layout.....	84
4.33. Analytic Range.....	84
4.34. Bars	85
4.34.1. Add	85



- 4.34.2. Delete86
- 4.35. Find86
 - 4.35.1. Data Value86
 - 4.35.2. Pulse Width89
- 4.36. Go to Bar/Edge90
 - 4.36.1. T-bar90
 - 4.36.2. A-bar91
 - 4.36.3. B-bar91
 - 4.36.4. Another Bar91
 - 4.36.5. Previous Edge91
 - 4.36.6. Next Edge91
- 4.37. Draw Analog Waveform91
- 4.38. Files Comparison93
- 4.39. Filter96
 - 4.39.1. Bus Width Filter96
 - 4.39.2. Noise Filter97
- 4.40. Image Decode98
- 4.41. Numeric Base/Encoding98
- 4.42. Signal Activity99
 - 4.42.1. Real-Time Frequencies99
 - 4.42.2. Signal Statuses100
- View101
- 4.43. Menu Layout101
- 4.44. Cursor type101
 - 4.44.1. Hand101
 - 4.44.2. Normal102
 - 4.44.3. Zoom102
- 4.45. Display type103
 - 4.45.1. State list103
 - 4.45.2. Waveform105
- 4.46. Refresh105
- 4.47. Zoom105



- 4.47.1. In.....106
- 4.47.2. Out.....106
- 4.47.3. Fit to Screen.....106
- 4.47.4. Previous106
- 4.48. Memory view106
- 4.49. Navigator109
- 4.50. Packet List110
- 4.51. Statistics.....113
- 4.52. Arrange Windows115
 - 4.52.1. Cascade116
 - 4.52.2. Horizontally.....116
 - 4.52.3. Vertically.....116
- 4.53. Split Screen116
 - 4.53.1. Show on All116
 - 4.53.2. Show on Primary.....116
 - 4.53.3. Show on Secondary.....116
- 4.54. (Open files)117
- MSO.....117
- 4.55. Menu Layout.....117
- 4.56. Single DSO Analog Channel.....117
- 4.57. Double DSO Analog Channel.....118
- 4.58. Close DSO Analog Channel.....119
- 4.59. Area Measurement.....119
- 4.60. DSO Module120
- Help.....123
- 4.61. Menu Layout.....123
- 4.62. Help123
- 4.63. Hot Keys124
- 4.64. Send Feedback126
- 4.65. About LAP-C.....127
- 4.66. About ZeroPlus128



5. Contact Us 130



Table of Figures

Figure 1-1 Package content items	17
Figure 1-2 Top view of the LAP-C	18
Figure 1-3 Side view of the LAP-C	19
Figure 1-4 Pin overview	23
Figure 2-1 Hardware connections.....	26
Figure 3-1 LAP-C software GUI	29
Figure 3-2 Timing bar	30
Figure 3-3 Channel/Bus Column detail.....	31
Figure 3-4 Right-click menu in the Channel/Bus Column	32
Figure 3-5 Reverse waveforms Waveform Area.....	33
Figure 3-6 Right-click menu in the Waveform Area	34
Figure 3-7 Place example – Reposition the Ds Bar	35
Figure 3-8 State List view; right-click menu in the number area	35
Figure 4-1 File drop-down menu.....	37
Figure 4-2 Save As dialog box.....	39
Figure 4-3 Screen Capture dialog box.....	39
Figure 4-4 Export Packet List dialog Box	41
Figure 4-5 Packet List Export Options dialog box	42
Figure 4-6 Export Waveform dialog box	42
Figure 4-7 Example Waveform export output file	44
Figure 4-8 Print dialog box.....	44
Figure 4-9 Settings / General dialog box	46
Figure 4-10 Settings / Options dialog box	47
Figure 4-11 Samples/Time ruler bar	48
Figure 4-12 Example of Snap-to-edges function.....	48
Figure 4-13 Tooltips example.....	49
Figure 4-14 Settings / Toolbars dialog box	49
Figure 4-15 Toolbar example – Acquisition toolbar	50
Figure 4-16 Settings / Colors dialog box	50
Figure 4-17 Settings / Shortcut Key dialog box	51
Figure 4-18 Settings / Auto Save dialog box	52
Figure 4-19 Acquisition drop-down menu	53
Figure 4-20 Bus properties (Protocol decoders) dialog box.....	54
Figure 4-21 Protocol decoder I2C configuration dialog box.....	55
Figure 4-22 Highlight Data example; Data Min = 0 packets are orange	57



Figure 4-23 Channel Assignment dialog box.....	58
Figure 4-24 Channel Assignment example.....	59
Figure 4-25 Acquisition Setup dialog box	59
Figure 4-26 Ex: Acquisition without compression – 81.92 us acquisition	61
Figure 4-27 Ex: Acquisition with compression – 5.05188ms acquisition	61
Figure 4-28 Signal Filter dialog box	62
Figure 4-29 Signal Filter / Delay Start Point – Start Edge	63
Figure 4-30 Signal Filter / Delay Start Point – End Edge	64
Figure 4-31 Signal Filter / Delay Start Point – Period + Delay	64
Figure 4-32 Signal Filter example / Pre-filter signal	64
Figure 4-33 Signal Filter example / Post-filter signal with A1 filter = High ...	65
Figure 4-34 Signal Filter – Bar with length annotation	65
Figure 4-35 Channel Trigger Setup dialog box.....	66
Figure 4-36 Bus Trigger Setup dialog box	67
Figure 4-37 Bus Trigger example	68
Figure 4-38 Protocol Decoder Trigger dialog box.....	68
Figure 4-39 Protocol Decoder Trigger example	69
Figure 4-40 Trigger Properties dialog box	70
Figure 4-41 Protocol Analyzer Trigger Mark	70
Figure 4-42 Trigger Count example	71
Figure 4-43 Trigger Delay dialog box.....	72
Figure 4-44 Trigger Position example – 0%	73
Figure 4-45 Trigger Position example – 10%	73
Figure 4-46 Repeated Triggering dialog box	74
Figure 4-47 Connect Multiple LAP-Cs dialog box	75
Figure 4-48 Stack LAP-Cs – Memory Mode example	76
Figure 4-49 Connection diagram with LAP-C as Master.....	77
Figure 4-50 Connection diagram with LAP-C as Slave.....	78
Figure 4-51 DSO Connection dialog box.....	78
Figure 4-52 DSO Connection / Settings dialog box.....	79
Figure 4-53 DSO Connection example – DSO signals imported.....	81
Figure 4-54 Waiting to acquire	83
Figure 4-55 Cumulative Packet Run dialog box.....	83
Figure 4-56 Cumulative Packet Run window example.....	84
Figure 4-57 Analysis drop-down menu	84
Figure 4-58 Add Bar dialog box	86
Figure 4-59 Find Data Value dialog box	87
Figure 4-60 Find example: B-bar seen at start of SPI data 0X12	88



Figure 4-61 Find Data Value dialog box / I2C (left) versus UART (right)	88
Figure 4-62 Find a Sequence of Data dialog box interface	89
Figure 4-63 Find Pulse Width dialog box.....	89
Figure 4-64 Find Pulse Width example.....	90
Figure 4-65 Go To example: Center the display around the T-bar	90
Figure 4-66 Draw Analog Waveform dialog box	92
Figure 4-67 Draw Analog Waveform – Single Display	92
Figure 4-68 Draw Analog Waveform – Mixed Display	93
Figure 4-69 Files Comparison dialog box.....	94
Figure 4-70 Files Comparison example.....	95
Figure 4-71 Bus Width Filter example – Before applying filter	96
Figure 4-72 Bus Width Filter example – After applying filter	96
Figure 4-73 Noise Filter dialog box.....	97
Figure 4-74 Noise filter example / Before applying 5 clock filter	97
Figure 4-75 Noise filter example / After applying 5 clock filter	97
Figure 4-76 Image Decode for 7-Segment LED protocol.....	98
Figure 4-77 Real-Time Frequencies window	99
Figure 4-78 Signal Statuses window.....	100
Figure 4-79 Acquisition drop-down menu	101
Figure 4-80 Hand mode - Press and hold the left key to navigate.....	102
Figure 4-81 Zoom In movement.	102
Figure 4-82 Zoom Out movement.....	103
Figure 4-83 State List display.....	103
Figure 4-84 Show changes in data only example (I2C)	104
Figure 4-85 Waveform display	105
Figure 4-86 Fit to screen – Zoom to fit all data in one window	106
Figure 4-87 I2C Memory View / Compact Mode	107
Figure 4-88 I2C Memory View / Complete Mode	107
Figure 4-89 Memory View Options dialog box.....	108
Figure 4-90 Navigator window shown under the waveform	109
Figure 4-91 Packet List example showing an I2C protocol.....	110
Figure 4-92 Packet List Settings dialog box	111
Figure 4-93 Packet Length example.....	112
Figure 4-94 Packet List Settings / Synchronize Navigation dialog box.....	112
Figure 4-95 Synchronize Navigation example in red frames	113
Figure 4-96 Statistics window	114
Figure 4-97 Statistics / Channel Selection – Select channels to include ...	114
Figure 4-98 Statistics / Customize – Select which columns to display	114



Figure 4-99 Statistics / Filter – Apply filter conditions	115
Figure 4-100 Statistics / Highlight Signals	115
Figure 4-101 Statistics / Highlight Signals example	115
Figure 4-102 MSO drop-down menu	117
Figure 4-103 Single DSO Waveform Window	117
Figure 4-103 Double DSO Waveform Window	118
Figure 4-104 MSO Area Measurement dialog	119
Figure 4-105 DSO Module View	121
Figure 4-106 DSO Module Setting Panel	121
Figure 4-107 Connect with DSO Module	122
Figure 4-105 Help drop-down menu	123
Figure 4-106 Help window	124
Figure 4-107 Send Feedback form	126
Figure 4-112 About LAP-C information window	127



Table of Tables

Table 1:1 Package content.....	17
Table 1:2 Operating systems supported.....	18
Table 1:3 Hardware requirements.....	18
Table 1:4 Product specifications 16 channel models.....	20
Table 1:5 Product specifications 32 channel models.....	21
Table 1:6 Available LAP-C models.....	22
Table 1:7 Optional functions.....	22
Table 1:8 Electrical specifications.....	23
Table 1:9 LAP-C Pin overview.....	24
Table 2:1 General advices for cleaning, operation and storage.....	28
Table 3:1 UI description; “Area” refers to the letter codes in Figure 3-1.....	30
Table 3:2 Timing Bar items.....	30
Table 3:3 Right-click menu in the Bus/Signal Column description.....	33
Table 3:4 Right-click menu in the Waveform Area - Description.....	35
Table 3:5 State List view; right-click menu in the number area.....	36
Table 4:1 Screen capture dialog box description.....	40
Table 4:2 Export Packet List dialog box description.....	41
Table 4:3 Export Waveform dialog box description.....	43
Table 4:4 Print dialog box description.....	45
Table 4:5 Settings / General dialog box.....	46
Table 4:6 Customize / Common Setup dialog box description.....	48
Table 4:7 Color settings dialog box description.....	51
Table 4:8 Settings / Shortcut Key dialog box description.....	52
Table 4:9 Settings / Auto Save dialog box description.....	52
Table 4:10 Bus properties (Protocol decoders) dialog box description.....	55
Table 4:11 Built-in protocol decoders.....	57
Table 4:12 Channel Assignment dialog box description.....	58
Table 4:13 Acquisition Setup dialog box description.....	60
Table 4:14 Normal mode vs. Double Mode.....	62
Table 4:15 Signal Filter dialog box description.....	63
Table 4:16 Bus Trigger Setup dialog box description.....	67
Table 4:17 Protocol Decoder Trigger dialog box description.....	68
Table 4:18 Connect Multiple LAP-Cs dialog box description.....	75
Table 4:19 DSO Connection dialog box description.....	79
Table 4:20 DSO Connection Settings dialog box description.....	80



Table 4:21 Supported DSO models	81
Table 4:22 List of DSO drivers	82
Table 4:23 Cumulative Packet Run dialog box description	84
Table 4:24 Description of the five standard bars	85
Table 4:25 Find Data Value dialog box description	87
Table 4:26 Find Pulse Width dialog box description	89
Table 4:27 Draw Analog Waveform dialog box description	92
Table 4:28 Files Comparison dialog box description	95
Table 4:29 Available data formats	99
Table 4:30 State List example; change of channel state	104
Table 4:31 Memory View description	108
Table 4:32 Memory View Options dialog box description.....	109
Table 4:33 Packet List description	110
Table 4:34 Packet List Settings description	111
Table 4:35 Packet List Settings/Sync Navigation dialog box description...	112
Table 4:36 Statistics window menu description	114
Table 4:37 MSO Area Measurement dialog description	120
Table 4:38 MSO Area Measurement dialog description	123
Table 4:38 Hot Keys - Letters.....	124
Table 4:39 Hot Keys - Combinations	125
Table 4:40 Hot Keys - Control and navigation keys.....	125
Table 4:41 Hot Keys - Function keys	126
Table 4:42 Send Feedback form description	127
Table 5:1 Contact info Sales Department	130
Table 5:2 Contact info Technical Support	130



Precautions

Users are advised to carefully review this section to avoid potential hazards to persons, this product, and other products connected to it.

- Grounding is required during signal acquisition to protect the LAP-C and the device under test.
- Follow the recommendations on operations, storage and maintenance from chapter 2.4.
- Protect the LAP-C from static discharge.
- Avoid direct impacts and rough handling.
- Do not place heavy objects on the LAP-C.
- The LAP-C may cause radio interference in a domestic environment.
- Do not disassemble the LAP-C as this will void the warranty and may affect its operation.



1. Introduction

This User Guide presents the ZeroPlus* LAP-C series logic analyzers, their operation and software. The purpose of the User Guide is to help users understand and get familiar with the operations of the instruments and the software.

This User Guide replaces the original LAP-C User Guide from 2008. To improve the user experience we have also rewritten the software strings.

Thank you for purchasing the LAP-C logic analyzer. Please feel free to write or call us with your questions, suggestions and other feedback.

** ZeroPlus is short for ZeroPlus Technology Co. Ltd*

1.1. Preface

This User Guide is designed to help new and intermediate users navigate and perform common tasks with the LAP-C logic analyzer. Despite its simple packaging and interface, the LAP-C is a sophisticated measurement and analysis tool. It is also a highly sensitive electrical current sensing device.

Users are advised to carefully read instructions and procedures pertaining to installation and operation. Any device connected to the LAP-C should be properly grounded and a pair of anti-static gloves is recommended when performing task. To ensure accuracy and consistency of output data, we also recommend to use the bundled components.

Note that we have recently rewritten many of the strings in the LAP-C software to make them more precise. There might therefore be some incongruence between this User Guide and the software. Please contact us at support@zeroplus.com.tw if you discover any differences or something is unclear. We will be happy to make the appropriate corrections.



1.2. About this Document

This User Guide is organized as follows: First, section 2 presents the characteristics of the LAP-C and the installation and setup procedures. Section 3 introduces the graphical user interface of the software. Section 4 then goes in-depth on the software functions.

The latest version of this document can be downloaded from the ZeroPlus website.



The functions in chapter 4 are sorted by their locations on the Main Menu of the software to make it easy to navigate. All right-click menus are found in chapter 3.1.2.

1.3. Product Introduction

The LAP-C is our bestselling logic analyzer series. Launched in 2008, it won the ELEXCON Excellent Product Award in 2008 and the Taiwan Excellence Award in 2009. It also became an immediate commercial success with more than 25,000 units sold to date. With functions, specifications and analysis tools that are remarkable for the price class, intuitive setup and software and a huge library of protocol decoders, eight years after release the LAP-C still offers unparalleled value for money.

See the product specifications in 1.6 and read about each individual function in section 4.

1.4. Package Content

Verify the package contents before discarding packing materials. The following components should be included with your product. For assistance, please contact your vendor or nearest distributor.

Model	16032	16064	16128	162000	32128	321000	322000
Instrument	1	1	1	1	1	1	1
Clip-on hooks	2	20	20	20	36	36	36
USB Cable	1	1	1	1	1	1	1
Driver CD	1	1	1	1	1	1	1
1-pin probe	1	1	1	1	1	1	1



2-pin probe	1	1	1	1	1	1	1
8-pin probe	2	2	2	2	2	2	2
16-pin probe	0	0	0	0	1	1	1
Quick Start Guide	0	1	1	1	1	1	1
Carry Bag	0	1	1	1	1	1	1
Warranty Card	1	1	1	1	1	1	1

Table 1:1 Package content

The following items are shown below: A picture of the some of the content is shown in Figure 1-1, namely the carry bag, LAP-C, clip-on hooks, USB cable, probes, warranty card and quick start guide.

**Figure 1-1 Package content items**

1.5. System Requirements

1.5.1. Operating System Support

The LAP-C supports operating systems from Microsoft only. See Table 1:2 below for a list of supported operating systems. Please contact our Technical Support team if you have questions about other operating systems than those listed below. This User Guide assumes that one of the operating systems below is properly installed.

Supported OS	Versions
Windows 7	Recommended



Windows 8.1 Uncertified workaround exists

Windows 10 Uncertified workaround exists

Table 1:2 Operating systems supported

1.5.2. Hardware Requirements

Item	Minimum	Recommended
CPU speed (MHz)	166	900
Memory (Mb)	64	256
Display resolution	1,024 x 768 VGA	1,024 x 768 VGA
Hard drive space (Mb)	100	100
Data transfer	USB 1.1	USB 2.0

Table 1:3 Hardware requirements

1.6. Product Specifications

1.6.1. Product Photos

Figure 1-2 and Figure 1-3 show the LAP-C from above and from the side. All inputs and outputs are located to the left as visible in Figure 1-2. The USB port for connection to PC can be seen in Figure 1-3.



Figure 1-2 Top view of the LAP-C



Figure 1-3 Side view of the LAP-C

1.6.2. Specifications

The product specifications are presented in Table 1:4 and Table 1:5. Table 1:4 shows the specifications of the 16 channel models and Table 1:5 the 32 channel models. The number of channels is indicated by the first two digits in the model name. Items that are not identical for the different models are shown in separated columns.

Model	16032	16064	16128	162000	
Supported OS	Win 7 (+ workaround for Win 8.1, Win 10)				
Sample Channels	16				
Sample Rate	Internal Clock (Timing) 100 Hz - 100 MHz				
	External Clock (State) 75 MHz		100 MHz		
Memory	Total	512 kb	1 Mb	2 Mb	32 Mb
	Per channel	32 kb	64 kb	128 kb	2 Mb
	Max compr. ratio		256		
Threshold Voltage	Bandwidth		75 MHz		
	Range		-6V to +6V		
	Precision		±0.1V		
Trigger	Trigger Channels		16		
	Trigger Events		State / Edge / Pattern		
	Pulse-width Trigger		No		
	Pre/Post Triggering		YES; choose from 0-100% pre-trigger data)		
	Trigger Delay		YES; based on memory or time		
	Trigger Seq. Levels		1		
	Trigger Out		YES; send a trigger signal that sets off another instrument		
	Trigger Pass Counter		65,535		



Software	UI Languages	English, Chinese (S), Chinese (T)	
Functions	Zooming and panning	3 cursor modes	
	UI customization	Modify the appearance of menus, traces etc	
	State list/Waveform	See samples as list of 0s and 1s or as traces	
	DSO Connection	Connect to and import signals from DSOs	
	Files Comparison	Compare 2 files to quickly see where and how they differ	
	Navigator	Quickly navigate to distant waveform parts	
	Memory View	See what the memory looks like	
	Packet List	Breakdown of all packet details into list form	
	Statistics	Table view of number of periods etc	
	Decoders	Decode more than 120 protocols for free	
Electrical	Phase Errors	< 1.5 ns	
Properties	Source	DC Connection	
	Power	5V DC, 500 mA (1W standby)	
	Maximum Input Voltage	±30V	
	Impedance	500 kΩ/10pF	
Certifications	FCC / CE / WEEE / RoHS		
Dimension	125 x 92 x 25 (mm)		
Standard	Flying Lead Probes	2x8-pin, 1x2-pin, 1x1-pin	
Accessories	Clips-on hooks	2	20
	USB cable	YES	
	Software/Driver CD	YES	
	Printed Guide	NO	YES
	Carrying Bag	NO	YES

Table 1:4 Product specifications 16 channel models

Model	32128	321000	322000
Supported OS	Win 7 (+ workaround for Win 8.1, Win 10)		
Sample Channels	32		
Sample Rate	Internal Clock (Timing) 100 Hz - 200 MHz		
	External Clock (State) 100 MHz		
Memory	Total	4 Mb	32 Mb
	Per channel	128 kb	1 Mb
	Max compr. ratio	256	
Threshold Voltage	Bandwidth 75 MHz		
	Range -6V to +6V		



	Precision	±0.1V
Trigger	Trigger Channels	16
	Trigger Events	State / Edge / Pattern
	Pulse-width Trigger	No
	Pre/Post Triggering	YES; choose from 0-100% pre-trigger data)
	Trigger Delay	YES; based on memory or time
	Trigger Seq. Levels	1
	Trigger Out	YES; send a trigger signal that sets off another instrument
	Trigger Pass Counter	65,535
Software Functions	UI Languages	English, Chinese (S), Chinese (T)
	Zooming and panning	3 cursor modes
	UI customization	Modify the appearance of menus, traces etc
	State list/Waveform	See samples as list of 0s and 1s or as traces
	DSO Connection	Connect to and import signals from DSOs
	Files Comparison	Compare 2 files to quickly see where and how they differ
	Navigator	Quickly navigate to distant waveform parts
	Memory View	See what the memory looks like
	Packet List	Breakdown of all packet details into list form
	Statistics	Table view of number of periods etc
	Decoders	Decode more than 120 protocols for free!
Electrical Properties	Phase Errors	< 1.5 ns
	Source	DC Connection
	Power	5V DC, 500 mA (1W standby)
	Maximum Input Voltage	±30V
	Impedance	500 kΩ/10pF
Certifications	FCC / CE / WEEE / RoHS	
Dimension	125 x 92 x 25 (mm)	
Standard	Flying Lead Probes	1x16-pin, 2x8-pin, 1x2-pin, 1x1-pin
Accessories	Clips-on hooks	36
	USB cable	YES
	Software/Driver CD	YES
	Printed Guide	YES
	Carrying Bag	YES

Table 1:5 Product specifications 32 channel models



1.6.3. Available Models

As indicated in the model number, the LAP-C16032, LAP-C16064, LAP-C16128, LAP-C162000 all have 16 channels. The LAP-C32128, LAP-C321000 and LAP-C322000 have 32 channels.

Model name	Channels	Memory per channel (kbits)
LAP-C16032	16	32
LAP-C16064	16	64
LAP-C16128	16	128
LAP-C162000	16	2,048
LAP-C32128	32	128
LAP-C321000	32	1,024
LAP-C322000	32	2,048

Table 1:6 Available LAP-C models

1.6.4. Optional Functions

Not all functions are included in all LAP-C models. Table 1:7 lists these functions and which models have these functions included for free in a base purchase.

Function	For free with following models	Details on function
Files Comparison	LAP-C162000, 321000, 322000	Chapter 4.38
Latch Function	LAP-C162000, 321000, 322000	Chapter 4.18
Protocol Trigger	LAP-C322000	Chapter 4.23
Trigger Mark	LAP-C162000, 322000	Chapter 4.25

Table 1:7 Optional functions

1.6.5. Electrical Specifications

Items	Minimum	Typical	Maximum
Working Voltage (DC)	4.5 V	5.0 V	5.5 V
Standby Power			1 W
Working Power			2 W
Phase Error			1.5 ns
V _{IN} of Test Channels	-30 V DC		30 V DC



V_{REF}	-6V DC	6 V DC
Input Resistance	500k/10pF	

Table 1:8 Electrical specifications

1.6.6. Pin Overview

**Figure 1-4 Pin overview**

Code	Name	Function
A0-A7	Port A	Signal input pins.
B0-B7	Port B	Signal input pins.
C0-C7	Port C	Signal pins (not for 16 ch. models; see Table 1:6).
D0-D7	Port D	Signal pins (not for 16 ch. models; see Table 1:6).
R_O	Read Out	A 3.3 V DC rising edge signal is sent over the R_O pin when the data transfer from the LAP-C to the PC is initiated. A falling edge signal is sent when the upload finishes.
T_O	Trigger Out	A 3.3 V DC rising edge signal is sent over the T_O pin when the LAP-C triggers. A falling edge signal is sent when the memory is full. See chapter 2.3.2.
S_O	Start Out	A 3.3 V DC rising edge signal is sent over the S_O pin when an acquisition is initiated by pressing RUN or the



START button on the casing.

CLK	Clock	In State mode, connect this pin to the DUT clock.
GND	Ground	Two ground pins are available.
VDD	Voltage Drain	+3.3 V output for powering external modules.
IO A/B/C	Ext. I/O Module	Use these pins to connect the PW Module to the LAP-C.

Table 1:9 LAP-C Pin overview



2. Installation and Setup

This chapter describes how to install the software and connect the hardware. It also treats the Trigger IN/OUT functions and provides recommendations for usage and storage of the LAP-C.

2.1. Software Installation

The following steps summarize the LAP-C installation procedure. It follows a standard Windows install shield wizard. For users who have internet access, we recommend that you download the latest version of the LAP-C software version from our website www.zeroplus.com.tw rather than installing from the CD.

1. Insert the installation CD in the drive or download the latest version of the software.
2. Execute the setup.exe file to start the installation. It is recommended to close all other programs during installation.
3. Choose the Application setup.
4. Click Next throughout the Installation Wizard to proceed with the installation. Note that it is necessary to accept the terms of the license agreement to proceed, and to choose between Custom or Complete installation. See note on the installation type below.
5. Click Install to confirm all settings and commence the actual installation.
6. Click Finish to complete the process.



Choosing a custom installation, the user can choose not to install one or more of the following items: Main application, Protocol Decoders, Examples, Tutorials, Driver. The examples and tutorials require around 30 Mb of disk space.



The LAP-C automatically connects to the ZeroPlus server to check for software updates.



The LAP-C software and driver should be installed prior to hardware connection.

2.2. Hardware Connections

Hardware installation/connection consists of the following simple procedure:

1. Plug the fixed end of the probes into the LAP-C.
2. Plug the flying leads into the circuit board connectors.
3. Ground the DUT to the LAP-C using the black ground cable.
4. Connect the USB cable between the PC and the LAP-C.

At this point, the computer should be able to detect the Logic Analyzer and finalize the installation for hardware connection.

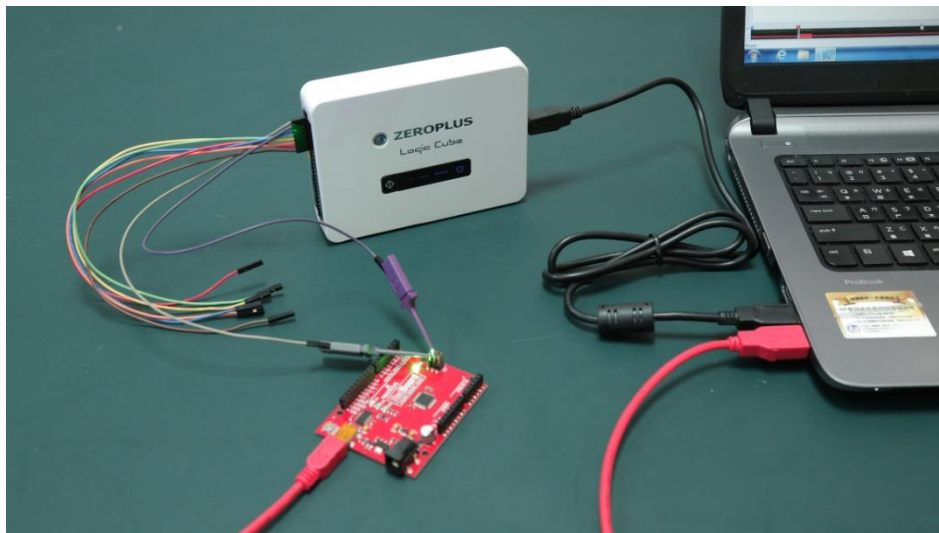





Figure 2-1 Hardware connections

 Note that grounding is important as it protects the LAP-C and the test board, and also ensures that both devices are referenced to the same voltage level. Grounding may also improve the quality and accuracy of the acquisition.

 If the LAP-C fails to acquire data, verify that the probes are properly connected, and that the test board is powered on. Note that the DUT is not powered through the LAP-C probes.

 If the flying leads cannot connect directly to the DUT, try to connect using the supplied clip-on hooks. To use one of these, first attach it to the flying lead. Then compress the hook to reveal two metal prongs that are used to grip the connector.

For State mode acquisitions, it is necessary to connect the clock of the DUT to the



clock pin of the LA. State mode can then be chosen in the Acquisition setup.

2.3. Trigger IN/OUT

The LAP-C can be connected to a DSO (or another instrument) for external or internal triggering.



It is also possible to display the analog waveforms of a DSO in the LAP-C software. This is not the same as Trigger IN; we call it a DSO Connection and it is described in chapter 4.27.

2.3.1. Trigger IN

The LAP-C can be triggered by an external source, most commonly a DSO or another logic analyzer. Any regular input channel can be used to Trigger IN: Simply connect the Trigger OUT of the other instrument to one of the LAP-C channels and set the appropriate trigger condition for this channel.

2.3.2. Trigger OUT

When the trigger conditions have been met, the LAP-C emits a signal that can be used to trigger another instrument. The signal is a 3.3 V DC rising edge signal that is sent over the T_O pin. Once the memory is full, a falling edge signal is sent.



Output signals are also sent over the R_O and S_O pins on the occurrence of other events. See an overview of the different output pins in Table 1:9.

2.4. Operating Environment and Maintenance

Please follow the below instructions when using, cleaning or storing your LAP-C and its accessories. Please also see the Precautions chapter prior to the Introduction.



Type	Description
------	-------------

Cleaning

Clean with a soft, damp cloth using a mild detergent.

Do not spray any liquid on the LAP-C.

Do not immerse the LAP-C in any liquid.

Do not use harsh chemicals or cleaners containing substances such as benzene, toluene, xylene or acetone.

Operating environment

Temperature (Working)	Min: 0° C	Max: 40° C
Temperature (Storage)	Min: 0° C	Max: 50° C
Rel. humidity (Working)	-	Max: 80%
Rel. humidity (Storage)	-	Max: 80%
Altitude	-	Max: 2,000 m
Insolation	Avoid direct sunlight.	
Environment	Use in a dust free, non-conductive environment.	

Table 2:1 General advices for cleaning, operation and storage



3. User Interface

3.1.1. Main Window

Figure 3-1 shows the graphical user interface of the LAP-C software.

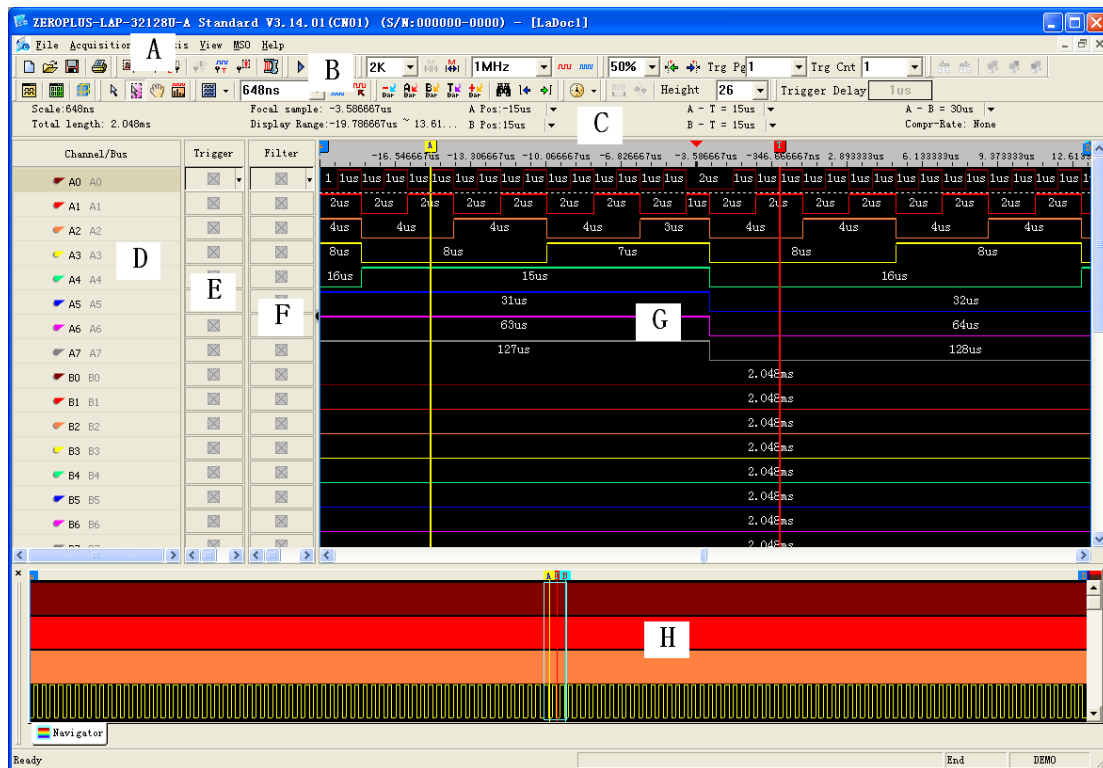

Figure 3-1 LAP-C software GUI

The LAP-C software can be divided into sections; see Table 3:1. Note that many functions can be accessed with Hot Key combinations described in chapter 4.63.

Name	Area	Description	Chapter
Main Menu	A	Access to all operations The organization of chapter 4 corresponds to the Main Menu.	4
Quick Access Toolbar	B	Convenient access to frequently used functions.	4.12.3
Timing Bar	C	Facilitates quick reading of the samples and traces. See Figure 3-2 below.	
Channel Column	D	See and edit channels/signals/groups; see Figure 3-3.	
Trigger Column	E	Quickly set trigger conditions.	



Filter Column	F	Set filter conditions.	4.21
Waveform Area	G	Displays the captured signals as traces or as a numeric list.	4.45
Secondary Display	H	Area where the Navigator, Memory View, Packet List and Statistics are shown.	4.48 to 4.51

Table 3:1 UI description; “Area” refers to the letter codes in Figure 3-1

A detail of the timing bar above the waveform is shown in Figure 3-2.



Figure 3-2 Timing bar

Item	Description
Scale	The scale is the inverse of the zoom level.
Total length	Total acquisition time.
Focal Sample	Location of the current center of the waveform.
Display Range	Timing information for the waveform currently in view.
A-pos	Position of the A-bar; click arrow to select another bar.
B-pos	Position of the B-bar; click arrow to select another bar.
A-T	Time difference A to T-bars; use arrow to select different range.
B-T	Time difference B to T-bars; use arrow to select different range.
A-B	Select a bar to see timing information.
Compr. Rate	See the compressed rate.

Table 3:2 Timing Bar items

Figure 3-3 shows a detail of the Channel/Bus Column. Channels can be grouped into buses and hidden/shown by clicking the black arrow next to the bus name.



Figure 3-3 Channel/Bus Column detail



Signals can be added, deleted, copied and grouped into buses using the mouse and the CTRL and SHIFT buttons, by drag-and-drop, or by right-clicking; see chapter 3.1.2.



Unknown signals are displayed as a mid-level grey, constant traces in the waveform.

3.1.2. Right-click Menus

This chapter contains the right-click menus that can be accessed by clicking in the different areas of the software.

3.1.2.1. Channel/Bus Column

Right-click in the Channel/Bus column to access acquisition setups and functions for channel manipulation; see menu in Figure 3-4.

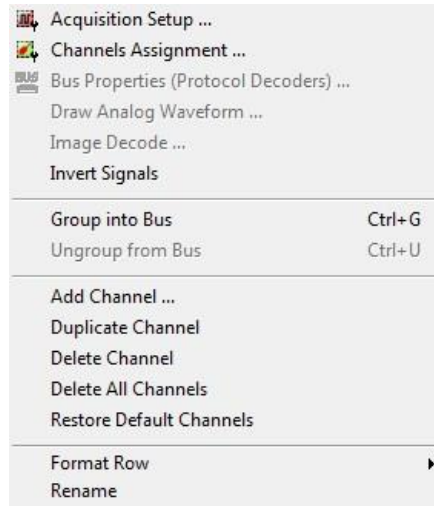

Figure 3-4 Right-click menu in the Channel/Bus Column

Item	Description
Acquisition Setup	Open the Acquisition setup dialog box; see chapter 4.20.
Channels Assignment	Open the Channel Assignment dialog box; see chapter 4.19
Bus Properties (Protocol Decoders)	Access the bus or protocol decoder properties; see chapter 4.18. Note that this item is only available when right-clicking on a bus.
Draw Analog Waveform	Draw an analog waveform based on the signal states; see chapter 4.37.
Image Decode	Display the acquired data as an image; see chapter 4.40. This function is only available for picture-type protocols.
Invert Signals	For traces, display high levels as low and vice versa. Inverted traces are drawn with dotted lines and a horizontal, blue bar is shown above the channel name. All channels can be inverted independently. See an example in Figure 3-5.
Bus	
Group into Bus	Group marked channels into a bus; see chapter 4.16.
Ungroup from Bus	Ungroup all channels from a bus; see chapter 4.17.
Channels	
Add Channel	Add a channel.
Duplicate Channel	Copy the selected channel or bus. Left-clicks with the mouse can be combined with pressing and holding SHIFT to select several channels or with CTRL to select



	a range of channels.
Delete Channel	Delete the selected channel(s).
Delete All Channels	Delete all channels and buses.
Restore Default	Restore all default channels.
Format Row	
Move Left/Up	Move the selected channel up or down in the column (left in the State List).
Move Right/Down	Move the selected channel down in the column (right in the State List).
Hide	Hide the selected channel.
Show All	Unhide all selected channels.
Color	Change color of signals or buses.
Rename	Rename channel or bus.

Table 3:3 Right-click menu in the Bus/Signal Column description



Invert traces to display high levels as low and vice versa. A horizontal, blue bar is shown above the channel name for inverted traces. All channels can be inverted independently. See Figure 3-5 where A2 in orange has been inverted in the lower screenshot.

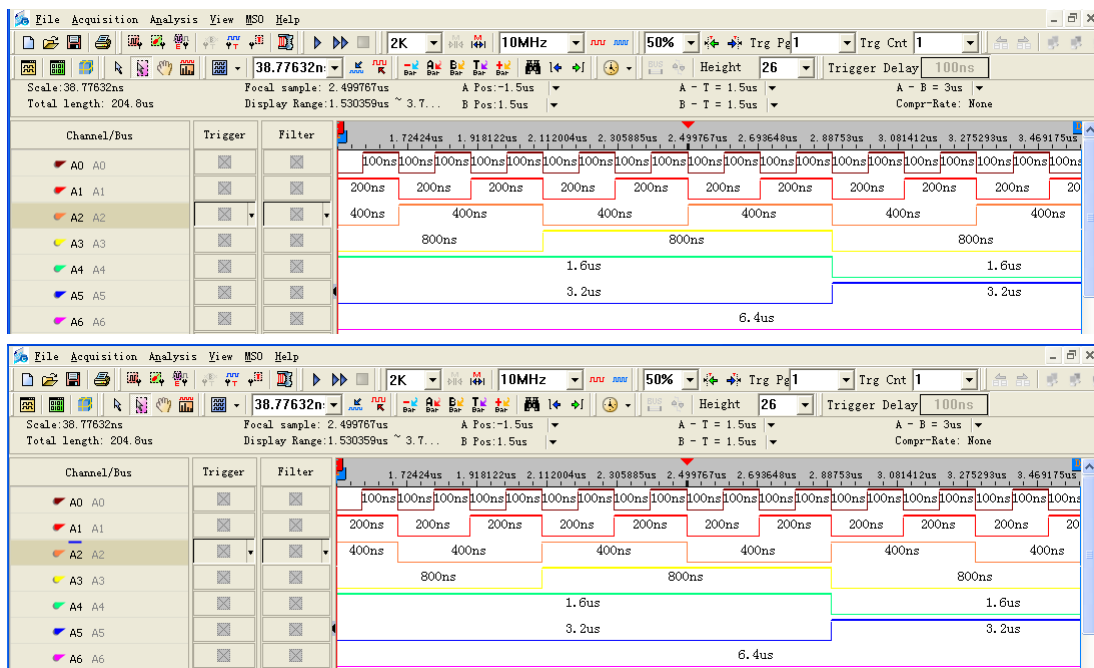

Figure 3-5 Reverse waveforms Waveform Area

3.1.2.2. Waveform Area

Right-click in the Waveform area to access the menu below.

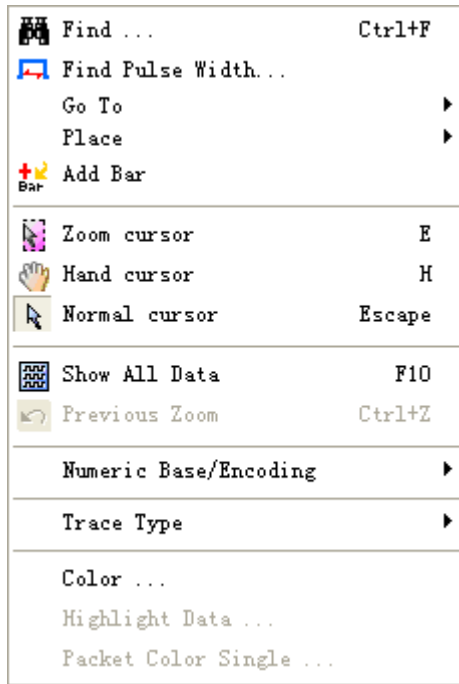

Figure 3-6 Right-click menu in the Waveform Area

Item	Description
Find	Look up a specific data value in the data; see chapter 4.35.1.
Find Pulse Width	Find pulses of a specific PW in the data; see chapter 4.35.2.
Go To	Go to a bar or an edge; see chapter 4.36.
Place	This function relocates a bar of choice to the position of the pointer when entering this menu. It is necessary to activate the Analytic Range to be able to move the Ds and Dp bars.
Add Bar	Add an extra bar where the pointer is clicked.
Pointer Mode	
Zoom	Change pointer to zoom mode; 4.44.3.
Hand	Change pointer to hand mode; see chapter 4.44.1.
Normal	Change pointer to normal mode; see chapter 4.44.2.
Show all Data	Zoom to fit all data on the screen; see chapter 4.47.3.
Previous Zoom	Undo the last zoom.
Numeric Base	Change the data format; see chapter 4.41.
Trace Type	Choose between saw-tooth and square shaped traces.

Colors



- Color Change the trace color.
- Highlight Data Color packet that satisfy a condition.
- Packet Color Single Color a single packet.

Table 3:4 Right-click menu in the Waveform Area - Description

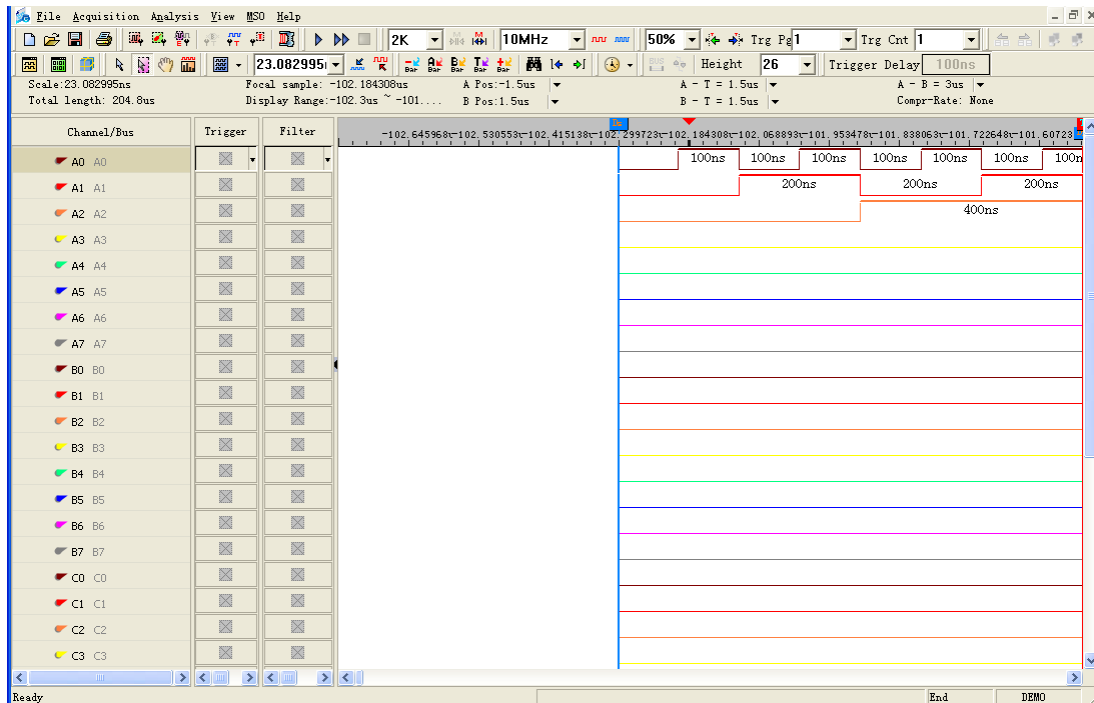

Figure 3-7 Place example – Reposition the Ds Bar

3.1.2.3. State List

Right-click in the State List number area to access the menu below.



Figure 3-8 State List view; right-click menu in the number area

Item	Description
Find	Look up a specific value in the data set; see chapter 4.35.1.



Go To	Go to a bar or an edge; see chapter 4.36.
Place	Reposition the selected bar to the cursor position.
Add Bar	Add a new bar to mark a sample in the list. The bar is added to the line where the cursor is placed. Contrary to the waveform bars, bars in the State List are horizontal since each line represents a time stamp.

Cursor Mode

Hand	In Hand mode, the left mouse button is used to move up/down in the State List.
Normal	Use this cursor mode with the scroll bars, mark objects etc.
Numeric Base	Choose how data should be displayed; see chapter 4.41.

Data Selection

All Data	All samples are shown; this is the default display mode.
Show changes in state only	Hide samples with timestamp X if no signal has changed state from timestamp X-1 to timestamp X.
Show changes in data only	Hide samples with timestamp X if no data has changed from timestamp X-1 to timestamp X (for buses only); see Figure 4-84.

Table 3:5 State List view; right-click menu in the number area



4. Software Operations

File

4.1. Menu layout

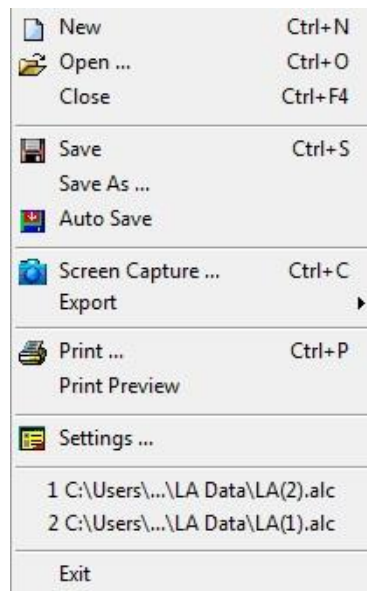

Figure 4-1 File drop-down menu

4.2. New

Create a new, empty file.

Hot Key: CTRL + N

4.3. Open

Open an existing file. When selecting a file in the Open file dialog box, file information such as author name, creation date, project title will be shown in the lower part of the dialog box. Some of this information is user-added to the file when saving; the rest is automatically added by LAP-C.



Hot Key: CTRL + O

4.4. Close

Close the active file. When closing a file that has not previously been saved, the software prompts the user to save it before closing.

Hot Key: CTRL + F4

4.5. Save

Save the active file. If the file has not been saved before, the Save As dialog box will open; see chapter 4.6 below. All setup parameters and configurations will be saved.

Hot Key: CTRL + S

4.6. Save As

Save As is useful for users who wish to save a file under a different name or type or change the destination folder, see Figure 4-2. The Save As dialog box also opens when the user saves a file for the first time so that these parameters can be defined.

The Save As dialog box lets users input file information such as author name and a note. This information is used for previews in the Open file dialog box; see chapter 4.3.

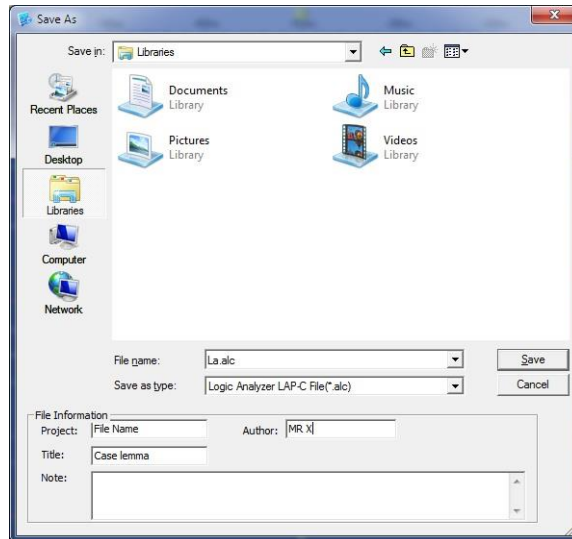

Figure 4-2 Save As dialog box

4.7. Auto Save

Click the icon to enable/disable the Auto Save function. When activated, each new acquisition is automatically saved under a new name. On the Main Menu, the Auto Save icon will appear slightly engraved when activated.

4.8. Screen Capture

Select a part of the screen – or all of it – and store it as a file or a picture; see the dialog box in Figure 4-3. If Clipboard is selected the file will be stored in the RAM. Some level of customization is possible as described in Table 4:1.

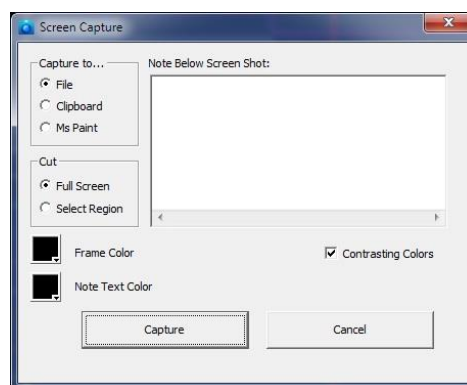

Figure 4-3 Screen Capture dialog box



Item	Description
Capture to	
File	Save the captured region in .bmp or .jpeg format.
Clipboard	Copy the captured region to the clipboard for editing in other softwares.
MS Paint	Open the captured region in MS Paint.
Cut	
Full Screen	Capture the full screen.
Select Region	Select a part of the screen to be captured by dragging a square with the left mouse button.
Note	Users can enter text to accompany the screen capture; if the field is not empty a blank area will be added below the screen capture where the text will be displayed.
Frame Color	Change the color of the Select Region frame; by default this is black.
Text Color	Change the color of the Note text.
Contrasting Colors	The Select Region frame color is the opposite of Line Color; selected by default.

Table 4:1 Screen capture dialog box description

4.9. Export

Users can choose between three types of exports: Waveform or Packet List. The characteristics of each type are presented below.

4.9.1. Packet List

This chapter treats the export of Packet Lists; please refer to chapter 4.50 for more details on the Packet List function itself. The Export Packet List dialog box is shown in Figure 4-4.

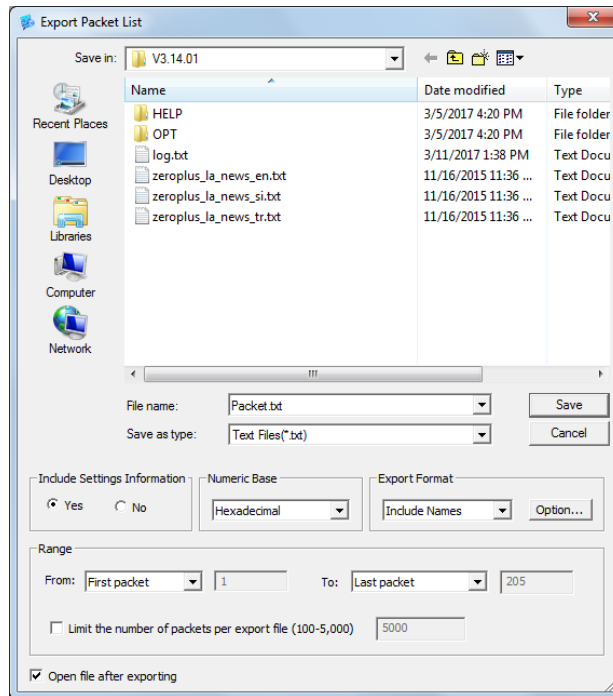

Figure 4-4 Export Packet List dialog Box

Item	Description
File name	Input a file name; the default is Packet.
Save as type	Export in .csv or .txt format.
Include Settings Info	Include acquisition parameters etc in the export file.
Numeric Base	Choose how data should be displayed; see chapter 4.41.
Export Format	Include names or output data only.
Options	Customize which items to include in the export; see Figure 4-5.
Range	Select range for the data to be exported.
Limit the number of packets per export file (100-5,000)	Set the maximum quantity of lines per export file; if the file length overshoots the limitation then several files will be created.
Open file after exporting	Open the exported file once it is ready.

Table 4:2 Export Packet List dialog box description



Figure 4-5 Packet List Export Options dialog box

4.9.2. Waveform

This chapter treats the export of waveforms; please refer to chapter 4.45.2 for information about the Waveform view itself. The Export Waveform dialog box is shown in Figure 4-6. An example output file is shown in Figure 4-7.

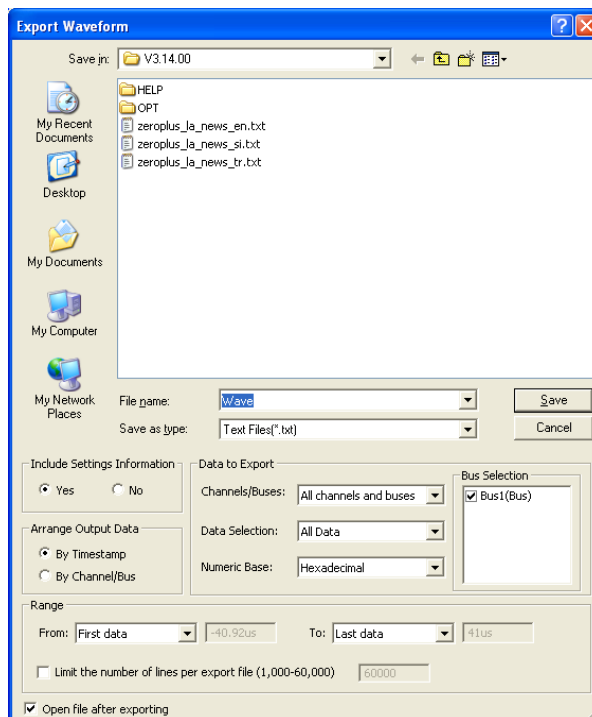

Figure 4-6 Export Waveform dialog box

Item	Description
File name	Input the file name; the default is Wave.
Save as type	Save the file as .txt or .csv; the default is .txt.
Include Settings Info	Include acquisition parameters etc. in the export file; checked by default.



Arrange Output Data

By Timestamp	Each column in the export file contains data for one timestamp; default option.
By Channel/bus	Each column in the export file contains data for one channel.

Data to Export

All channels and buses	Export channel, bus and protocol decoder data.
All buses (excl. ch.)	Export bus and protocol decoder data.
Buses with protocol decoders (incl. ch.)	Export protocol decoder data (channel data included).
Buses with protocol decoders. (excl. ch.)	Export protocol decoder data (channel data not included).

Data Selection

All Data	Export all data.
Show changes in state only	Export data for timestamp X only if at least one signal has changed state from timestamp X-1 to timestamp X.
Show changes in data only	Export data for timestamp X only if at least one data has changed state from timestamp X-1 to timestamp X (for buses only).

Numeric Base	Choose between binary, decimal, hexadecimal etc data format
--------------	---

Bus Selection	Select buses to be included in the export file.
---------------	---

Range

From, To	Select the range for the data to be exported, measured in time or based on bars.
Limit the number of lines per export file	Limit the size of exported files; if the data don't fit on the amount of lines selected by the user then multiple files will be created.

Open file automatically after exporting	Open the exported file once it is ready.
---	--

Table 4:3 Export Waveform dialog box description



```
Wave.txt - Notepad
File Edit Format View Help
//
// =====
// Thanks for using ZEROPLUS Logic Analyzer
// Version: V3.14.00
// =====
//
// File name: Wave.txt
// File size: 198 KB
//
-----
// File created on: 2016/05/26
// Logic Analyzer Setup Information
// Sampling mode: Compression
// Internal sample rate = 50000 Hz
// Memory depth = 2KB
// Compression enabled
// Number of buses = 1
// Number of channels = 24
// Trigger Properties: Trigger position = 50%
// Trigger Voltages: IIA Port = 1.50 V IIB Port = 1.50 V IIC Port = 1.50 V
//
// Trigger Pass Counter = 1
// Trigger Page = 1
// Signal Filter setup: Unabled
// Delay time: Disabled
// H=High, L=Low, E=Indifferent
// Signal Trigger setup: D=Indifferent, H=High, L=Low// R=Rising Edge, F=Falling Edge,
// E=Either.
// Trigger setup: As presented below.
// Message: Total: 40.96ms Scale: 20ns Compression rate: 1.000
Settings must be equal to reproduce acquisition.
-----
// Channel name: I Bus1 *SDA *SCL A2 A3 A4 A5 A6 A7 B0 B1
B2 B3 B4 B5 B6 B7 C0 C1 C2 C3 C4 C5 C6 C7
// Signal Filter: I X X X X X X X X X X X X X X X X
X X X X X X X X X X X X X X X X
// Trigger: I X D D D D D D D D D D D D D D
D D D D D D D D D D D D D D D
//Sieve out the display of the data.
-----
Data are shown as hexadecimal values.
A Bar position: -300us T Bar position: 0ns B Bar position: 300us
```

Figure 4-7 Example Waveform export output file

4.10. Print

This function prints the Waveform or State List on white background. The Timing Bar (above the waveform) and the Channel/Trigger/Filter Columns are also printed. The Waveform/State List background is printed as white and an extra field containing the file name, date and page number is added to the top of the page. Note that the background color and print range can be modified.

The print option dialog box has a standard Windows layout that lets the user choose what to print and also gives access to other printer properties; see Figure 4-8.

Hot Key: CTRL + P



Figure 4-8 Print dialog box



Item	Description
Name	Select a printer.
Properties	Open the Print Properties dialog box for more print options.
Print range	
All	Print the entire waveform or state list.
Pages	Print parts of the waveform or state list. What is currently being viewed is regarded as one page.
Current Page	Print the current view.
Copies	
Number of copies	Number of copies to be printed.
Collate	Organization of multiple copies. Ex: 2 copies of 3 pages will print 1, 2, 3, 1, 2, 3 when collate is checked (default option) and 1, 1, 2, 2, 3, 3 when unchecked.

Table 4:4 Print dialog box description

4.11. Print Preview

Preview what the printed file will look like. When opening the Print Preview, a new toolbar will appear above the preview; this is used for zooming and navigation between pages. Press Esc to leave the Print Preview.

4.12. Settings

The appearance and behavior of the user interface and functions can be customized from the configurations, options and settings that are all gathered in Settings.

4.12.1. General

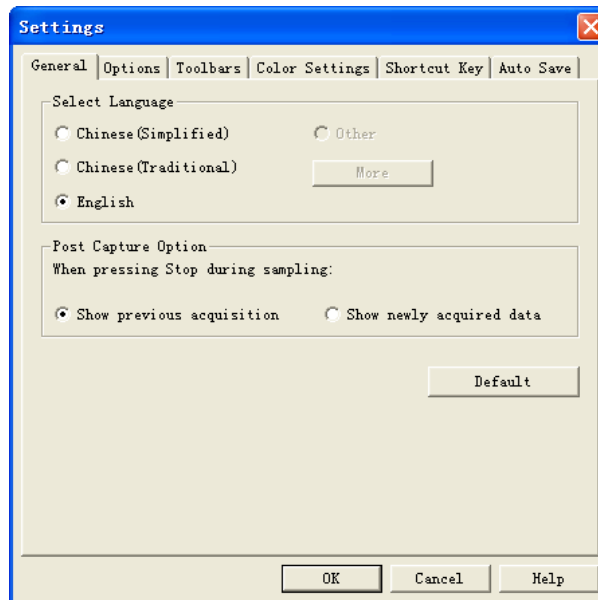

Figure 4-9 Settings / General dialog box

Item	Description
Select language	
Chinese/English	Software strings can be displayed in English, Simplified Chinese or Traditional Chinese; the one selected during installation is the default. To change language the software must restart.
Other/More	This buttons are for distributors or users who develop their own language packs.
Post Capture Option	
Show previous acquisition	This option governs the software behavior when the user presses Stop in the middle of an acquisition. If this option is selected then the previous acquisition will be displayed again.
Show newly acquired data	When pressing Stop during an acquisition, the data acquired up until the Stop moment are displayed; this is the default option.

Table 4:5 Settings / General dialog box

4.12.2. Options

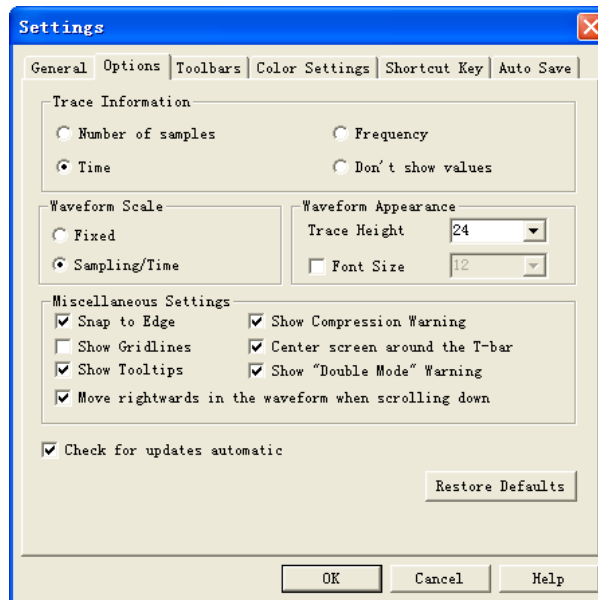

Figure 4-10 Settings / Options dialog box

Item	Description
Trace Information	
Number of samples	Show number of samples between two edges.
Frequency	Show frequencies between two edges. The frequency of a full period (rising to rising edge) is displayed.
Time	Show the time between two edges.
Don't show values	No information is shown inside the traces; default option.
Waveform Scale	
Fixed	The center of the screen is fixed at 0 sec.
Samples/Time	0 seconds is defined as the trigger event; this is the default option. See an example in Figure 4-11.
Waveform Appearance	
Trace Height	Set the trace amplitude from 18 to 100 px.
Font Size	Set the font size from 6 to 60.
Miscellaneous Settings	
Snap to Edges	Bars snap automatically to the nearest trace edge when being repositioned. See example in Figure 4-12.
Show Gridlines	Show gridlines in the waveform area.
Show Tooltips	Shows trace information when hovering over the waveform; see Figure 4-13.
Move Rightwards	Invert panning direction when scrolling mouse wheel.



Compression Warning	Show notification when Compression Mode is activated.
Center around T-bar	Show the T-bar in the middle of the Waveform Area after triggering.
Double Mode Warning	Show notification when Double Mode is activated.
Check for Updates	Automatically check for SW updates upon startup.
Restore Defaults:	Restore all settings to default.

Table 4:6 Customize / Common Setup dialog box description

Figure 4-11 shows the Samples/Time ruler bar.

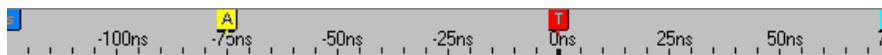

Figure 4-11 Samples/Time ruler bar

Figure 4-12 below shows an example of the Snap-to-edges function. In the left illustration the function is turned off; in the right it is on. In the right illustration, the C-bar does not stay where it is dropped; it snaps to the closest edge which is the rising edge right to the left of where it was dropped.

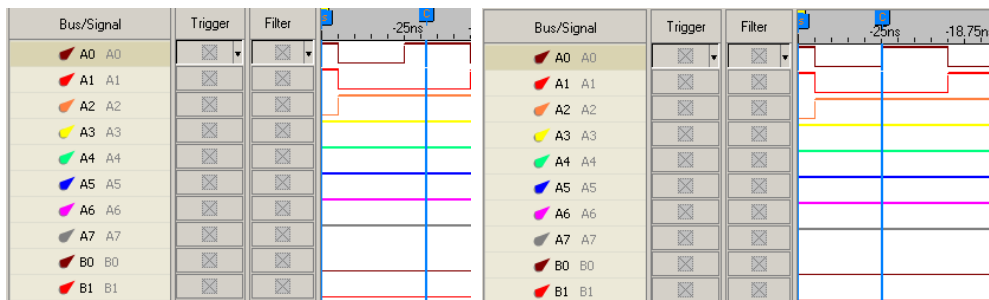

Figure 4-12 Example of Snap-to-edges function

Tooltip example: When users click in the waveform or make a selection to zoom in or out, the Tooltip displays time, sample rate and channel number.

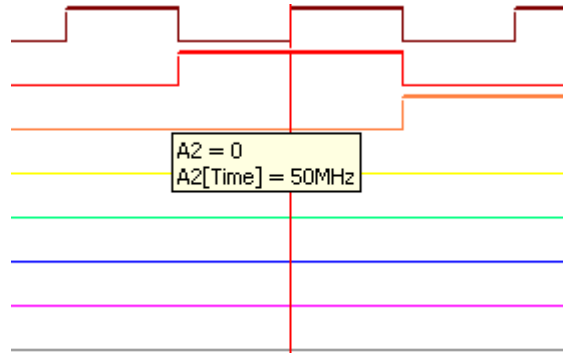

Figure 4-13 Tooltips example

4.12.3. Toolbars

The Toolbars consist of shortcut icons to commonly used functions. They are shown by default below the Main Menu as shown in Figure 3-1. The dialog box used to decide which toolbars to show is shown in Figure 4-15. There are 13 available toolbars: File, Acquisition, Start/Stop, Acquisition Settings, Trigger Properties, Trace Information, View Mode, Cursor mode, Zoom, Bars/Find, Protocol Decoders, Trigger Delay and Text Size and Files Comparison/Screen Display.

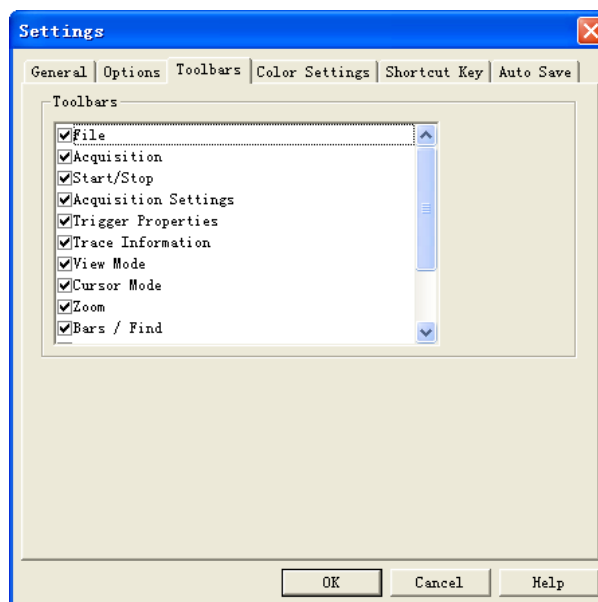

Figure 4-14 Settings / Toolbars dialog box

An example of a toolbar is shown below; Figure 4-15 shows the Acquisition toolbar. When this toolbar is ticked in the Settings / Toolbars menu, it is shown above the



waveform. The purpose is to give the user direct access to important settings, in this case the memory depth and acquisition rate.



Figure 4-15 Toolbar example – Acquisition toolbar

4.12.4. Colors Settings

Users can customize the colors of bars, texts, traces and other elements of the user interface. To change the color of an element, click the corresponding color bar in the Color column of the dialog box tabs shown in Figure 4-16 to access the color palette. Proceed to select a predefined color or define a custom color for the element.

Figure 4-16 shows the two tabs of the Color Settings dialog box. The Environment tab lets users modify background and text colors etc, whereas the Waveform tab lets users change the colors of the individual traces and the thickness of each trace.

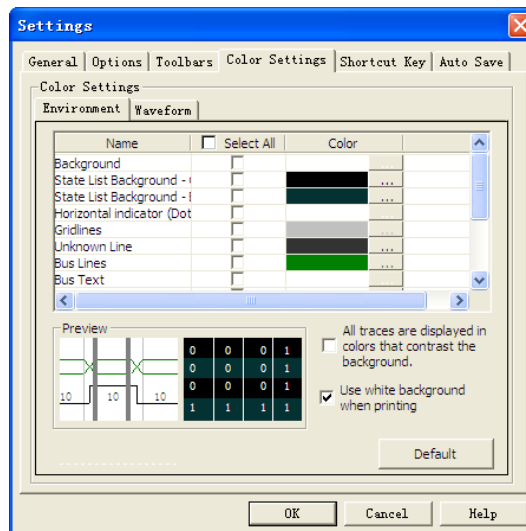

Figure 4-16 Settings / Colors dialog box

Item	Description
Tab Selection	
Environment	Modify the color of backgrounds, texts etc.
Waveform	Modify the color and line width of traces.

[Menu](#)



Name	Customizable element.
Select All	Tick the boxes to change the color of multiple elements at once.
Color	Current color of the element; click it to change the color.
Preview	Preview the color selections; the left frame shows the Waveform and the right the State List.

Options

All traces are...	All traces are displayed in colors that contrast the background.
Use white...	When printed the waveform is white.

Table 4:7 Color settings dialog box description

4.12.5. Shortcut Key

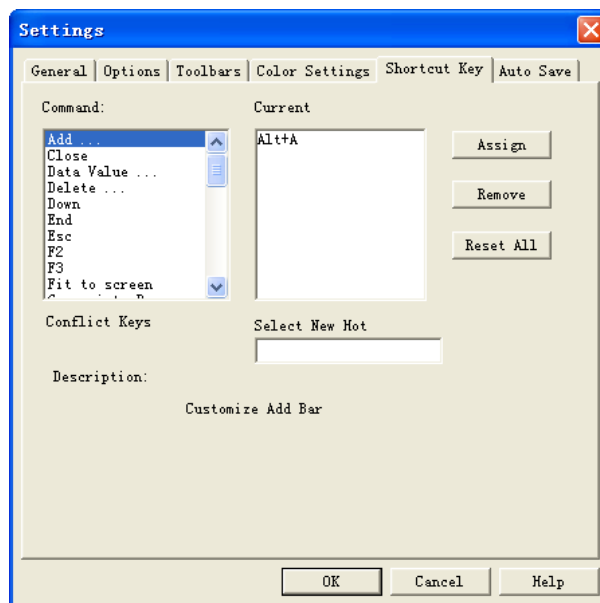

Figure 4-17 Settings / Shortcut Key dialog box

Item	Description
Commands	Select a Command (function) for which a Shortcut Key can be assigned.
Select New Hot Keys	Input the new Shortcut Key combination (or single key) and click Assign to make the change effective.
Current Keys	Displays the current Shortcut Key for the selected command.
Conflict Keys	If the new Shortcut Key are already in use, the command currently using them will be shown.
Select New	Select new Shortcut Key if there are conflicts.
Description	Displays a brief description of the selected command.

Table 4:8 Settings / Shortcut Key dialog box description

4.12.6. Auto Save

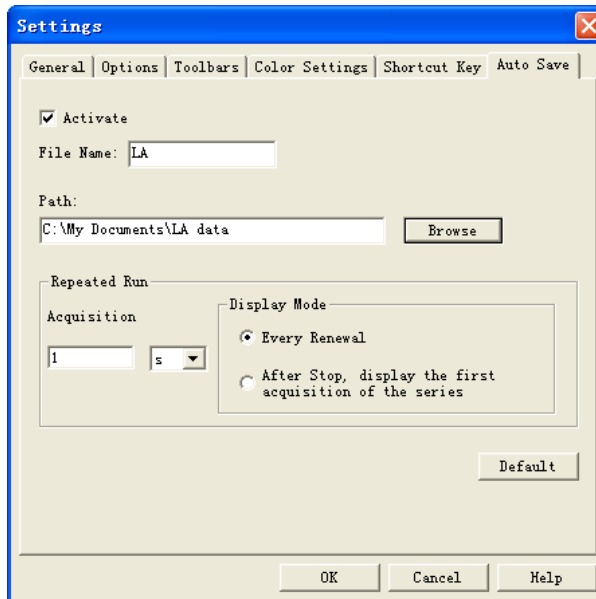

Figure 4-18 Settings / Auto Save dialog box

Item	Description
Activate	Activate to Autosave all acquisitions.
File Name	The defaulted name is LA. When the LAP-C creates new files, they are named LA1, LA2 etc.
Path	Choose where to save files.
Repeated Run	It is possible to define the time interval from one acquisition finishes to the next one starts when the LAP-C captures repeatedly.
Display Mode	
Every Renewal	When the Repeated Run is activated, the waveform image keeps renewing.
After Stop...	For Repeated Runs, keep displaying the waveform from the first acquisition rather than renewing to display new acquisitions.

Table 4:9 Settings / Auto Save dialog box description



4.13. Recent files

This part of the File menu shows recently opened files.

4.14. Exit

Exit the program. The software prompts users to save unsaved files.

Hot Key: ALT + F4

Acquisition

4.15. Menu Layout

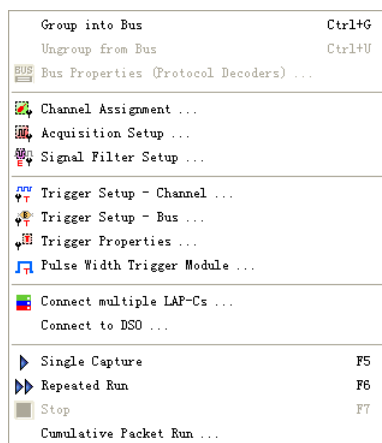

Figure 4-19 Acquisition drop-down menu

4.16. Group into Bus

Channels can be grouped into buses from this item on the Main Menu or by selecting multiple channels and right-clicking. It can also be done by selecting channels in the trigger column and pressing CTRL plus G, or by simply dragging a channel into an existing bus

Hot Key: CTRL + G.



4.17. Ungroup from Bus

Ungroup signals from a bus.

Hot Key: CTRL + U

4.18. Bus Properties (Protocol decoders)

If you are using a specific protocol, you can add a protocol decoder to your bus to see decoded data packets. Figure 4-20 shows the Bus Properties dialog box from which the decoders can be added. Certain other properties of buses are also handled from this dialog box, most notably what we call Highlight Data and the Latch function. These functions are both presented further down in this subchapter.



The LAP-C comes with more than 120 free protocol decoders. These are listed in Table 4:11.



It is necessary to group signals into a bus before a decoder can be added.

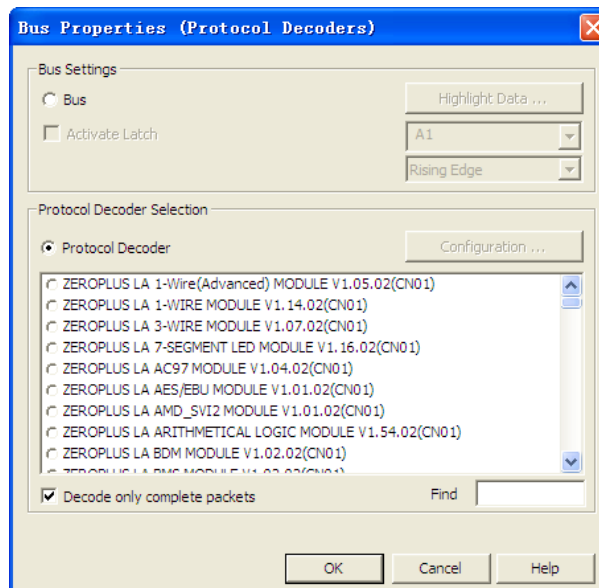

Figure 4-20 Bus properties (Protocol decoders) dialog box



Item	Description
Bus Settings	
Highlight Data	Highlight data that satisfies a user-defined condition to make them stand out. See an example in Figure 4-22.
Activate Latch	The Latch function is used to analyze/decode bus activity that does not use a specific protocol. When selecting a channel and an event, the bus data will be decoded and displayed at every occurrence of this event. Read more at the end of this subchapter.
Protocol Decoder Selection	
Protocol Decoder Configuration	Activate to add a protocol decoder to the bus. All protocol decoder setup dialog boxes have distinct designs and take different variables. Figure 4-21 shows an example of one protocol decoder configuration dialog box for the I2C protocol.
Decode only complete packets	Unchecked, all packets are shown in the Packet List. When checked, only packets between the Ds and Dp bars are shown. This is useful when adjusting the Analytic Range.
Find	Start typing the name of a protocol to quickly navigate to the decoder.
All protocols built into latest version	From 2016, all our protocol decoders are built into the LAP-C software.

Table 4:10 Bus properties (Protocol decoders) dialog box description

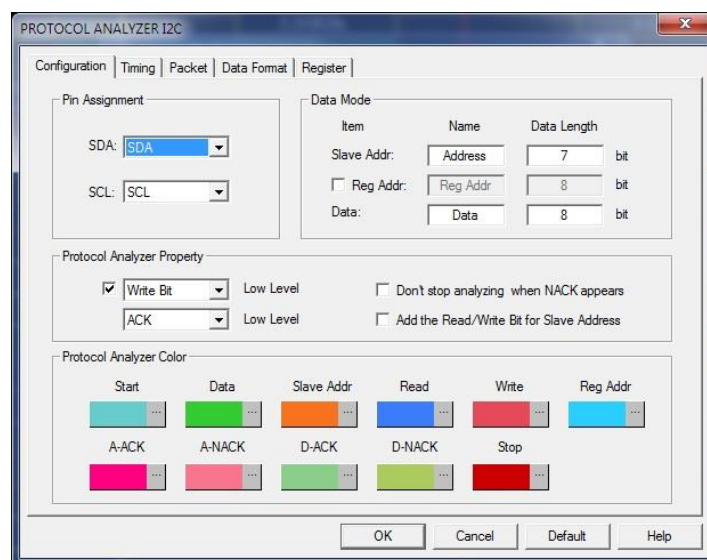

Figure 4-21 Protocol decoder I2C configuration dialog box



Table 4:11 lists the protocol decoders built into the LAP-C software.

Built-in Protocol Decoders		
1-WIRE	IRDA	Philips RC-6
1-WIRE (Advanced)	ISO7816 UART	PMBus 1.1
3-WIRE	JK FLIP-FLOP	PROFI BUS
7-SEGMENT LED	JTAG 2.0	PS/2
AC97	KEELOQ Code Hopping	PSB Interface
AES_EBU	KNX	PT2262/PT2272
AMD_SV12	LCD 12864	QI
ARITHMETICAL LOGIC	LCD1602	Quad SPI
BDM	LED Pitch Array	RGB Interface
BMS	LG4572	S/PDIF
CAN 2.0B	LIN 2.1	S2Cwire/AS2Cwire
CCIR656	Line code	Samsung K9 (Nand Flash)
CMOS IMAGE	Low Pin Count	SCCB
Compact Flash 4.1	LPC-SERIRQ	SD2.0/SDIO
DALI Interface	LPT	SDQ
DDC EDID	MANCHESTER	Serial GPIO IBPI
Differential Manchester	MCU-51 DECODE	Serial Wire Debug (SWD)
DIGITAL LOGIC	MDDI	SHT11
DigRF	MHL-CBUS	SIGNIA 6210
DM114/DM115	Microwire	SLE4442
DMX512	Microwire (EEPROM 93C)	SMBus 2.0
DP AUX Channel	MIDI	SPI
DS1302	MII	SPI PLUS
DS18B20	MILLER	SPI (EEPROM AT25F)
DSA Interface	MIL-STD-1553	SSI Interface
DSI Bus	MIPI DSI	ST7669
FLEXRAY 2.1A	MIPI_CSI-2	STBus
FWH	ModBus	SVID
GPIO	MODIFIED MILLER	SWP
HART	MODIFIED SPI	UART
HD Audio	MVB	UNI/O
HDMI CEC	NEC PD6122	UPDOWNCOUNTER
HDQ	OPENTHERM 2.2	USB 1.1 plus
HPI	PCI	USB 2.0
I2C	PCM	Wiegand



I2C (EEPROM 24L)	PECI	WTB
I2C(EEPROM24LCS61/24 LCS62)	Philips RC-5	WWW/WWWVH/WWWVB
I2S	YK-5	eMMC
SD3.0	eSPI	HID Over I2C
HDLC	USB PD3.0	CCIR601
CAN FD		

Table 4:11 Built-in protocol decoders

Figure 4-22 shows how the Highlight Data function works to highlight data by coloring them. In the example, the condition =0 has been applied to Bus1 with an orange color. Had the function not been used, these data would have had the same white background color as the neighboring data that are not equal to 1.

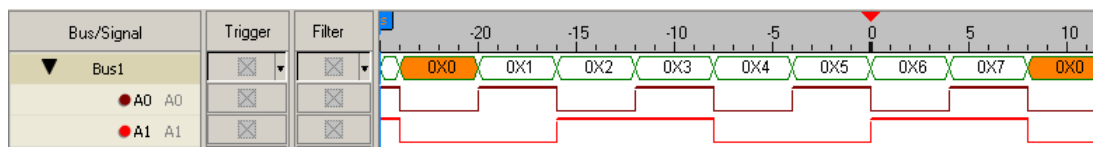

Figure 4-22 Highlight Data example; Data Min = 0 packets are orange

The Latch function is used to analyze/decode bus activity that does not use a specific protocol. By default, the bus is decoded whenever one of the channels transition from one state to another. By using the Latch function, the decoding can instead be done for every occurrence of a particular event on a particular channel.



The channel that is closest to the bus name in the trigger column counts as the LSB. Rearrange channels in the list by dragging and dropping to change this.



The Latch function comes for free with the LAP-C162000, LAP-C321000 and LAP-C322000 models. It can be purchased separately for the LAP-C16032, LAP-C16064, LAP-C16128 and LAP-C32128 models.

4.19. Channel Assignment

The Channel Assignment dialog box is shown in Figure 4-23. It serves the following main two purposes: 1) to link physical probes with software channels and 2) create



buses and in other ways arrange the channels/signals.

One probe is connected to each of the channel ports of the LAP-C and each probe samples one signal. The left column shows the channel name in LAP-C and the purple coloring determines which of the ports/probes is linked to the channel. Each column in the dialog box (Port A-D) represents a physical channel. By default, Port A0 (Probe0) is linked with channel A0 in the software etc, but from this dialog box channels can be renamed and rearranged.

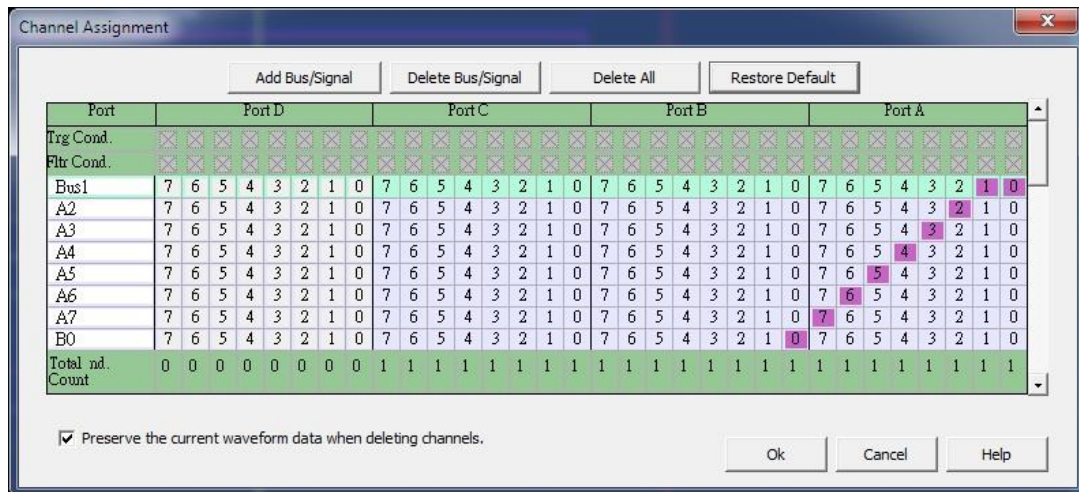

Figure 4-23 Channel Assignment dialog box

Item	Description
Buttons	
Add Bus/Signal	Click to add a channel which will appear as “New0”.
Delete Bus/Signal	Delete the selected bus/signal.
Delete All	Delete all buses and channels.
Restore Defaults	Restore all channels and buses to system default.
Action area	
Left column	Modify the channel/bus name.
Purple checkboxes	Tick to assign to channel/bus in software and to create groups.
Preserve waveform data	When making changes to the channel setup, uncheck this checkbox if you want the original waveform data to be erased.

Table 4:12 Channel Assignment dialog box description

Figure 4-24 shows an example of how signals can be assigned to a SW channel; a bus has been created with channels A0 to A4.

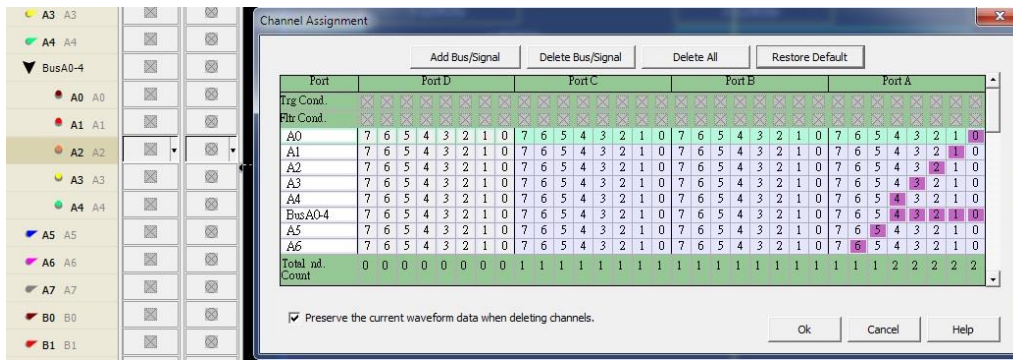

Figure 4-24 Channel Assignment example



Unused channels can be removed from the software display to avoid distracting elements.

4.20. Acquisition Setup

Fundamental sampling choices such as acquisition mode, memory depth and acquisition rate are selected in this dialog box shown in Figure 4-25 below. This is also where users can enable compression and setup signal filters.

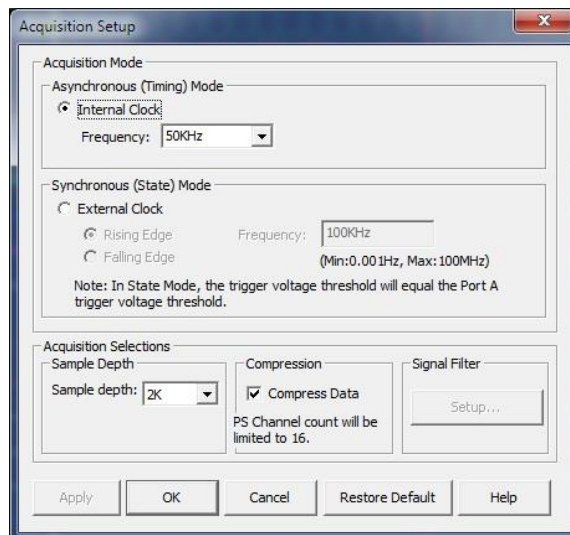

Figure 4-25 Acquisition Setup dialog box

Item	Description
Acquisition Mode	
State	The sample rate or acquisition frequency determines how often a



(External Clock)	signal is sampled. In State mode (also called synchronous acquisition) the clock that governs when to sample data is provided by the DUT. State mode provides a view of how the system is executing. One sample is taken per clock cycle and the user must specify whether he wants to sample on rising or falling DUT clocks, or on either. The State mode sample rate ranges from 0.001 Hz to 75/100 MHz depending on the model. See chapter 2.2 for how to connect a synchronous clock.
Timing (Internal Clock)	In Timing mode (also called asynchronous acquisition) the input signals are sampled and stored at equal time intervals based on LAP-Cs internal clock. The Timing mode sample rate goes from 100 Hz to 100/200 MHz depending on the model. Remember that the sample rate should be at least 4 times higher than the DUT signal frequency for the sampling to be accurate.

Acquisition Choices

Sample Depth	Determine the amount of data to be acquired per channel.
Compression	The Compression function can be used to extend the length of acquisitions. The principle goes as follows: Rather than storing 100 consecutive 1s, the LAP-C stores 1x100 using a hardware based algorithm. The function is therefore most efficient when sampling buses that are idle for significant amounts of time, when a maximum compression rate of 255 can be reached. In other words, 1 Mb of memory can be used to acquire up to 255 Mb of data. Note that the function is disabled by default as a negative compression rate is possible for signals with high variability. Note that no data will be lost when using Compression. See Figure 4-26 and Figure 4-27 below for an example.
Signal Filter	Filter out unwanted signals; see chapter 4.21.

Table 4:13 Acquisition Setup dialog box description



Select an acquisition rate that is at least 4 times higher than the signal frequency to ensure that the signals are sampled correctly.

Figure 4-26 and Figure 4-27 show an example where the acquisition length increase from around 81.92 us to 5.05188ms by turning on compression, thus increasing the capture length by a factor of 122.

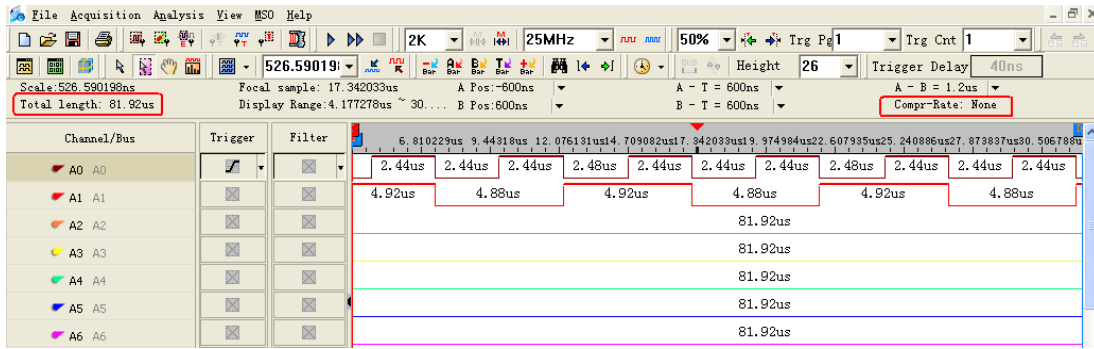

Figure 4-26 Ex: Acquisition without compression – 81.92 us acquisition

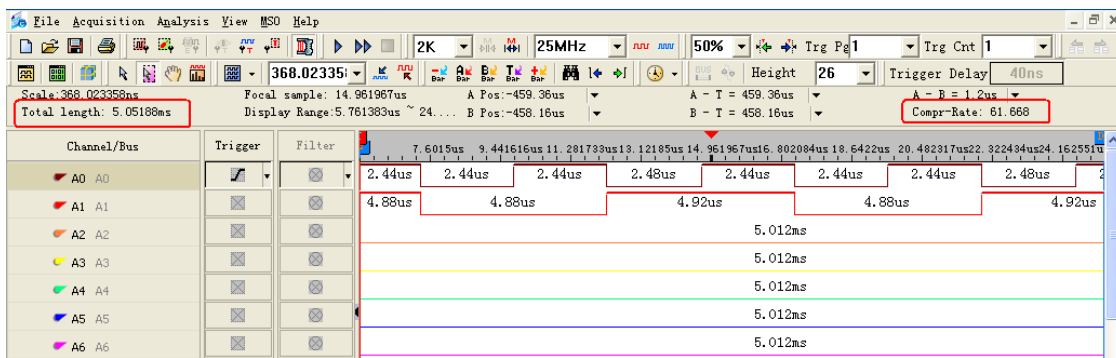

Figure 4-27 Ex: Acquisition with compression – 5.05188ms acquisition

Table 4:14 shows the available memory in Double Mode for each model of the LAP-C series. Double Mode lets users concentrate the total memory on a limited number of channels in use. For 32 channel models, the available memory is double if only 16 channels are open. Double Mode does not have to be enabled; it just means that larger memory options are available in the Memory Size drop-down menu. When the Double Mode kicks in the user is notified with a pop-up.

Model	Normal Mode		Double Mode	
	Available Memory	Available Channels	Available Memory	Available Channels
LAP-C16032	32 kb	16	Double mode unavailable	
LAP-C16064	64 kb	16	Double mode unavailable	
LAP-C16128	128 kb	16	Double mode unavailable	
LAP-C162000	2 Mb	16	Double mode unavailable	
LAP-C32128	128 kb	32	256 kb	16



LAP-C321000	1 Mb	32	2 Mb	16
LAP-C322000	2 Mb	32	4 Mb	16

Table 4:14 Normal mode vs. Double Mode



Compression Mode and Signal Filter Mode is disabled in Double Mode.

4.21. Signal Filter Setup

Filtering is used to increase the record length by only storing samples when certain user-defined signals are high or low. Example: The simplest type of Signal Filtering is to set A0 to High. The LAP-C will then only store samples when A0 is High, and never store anything when A0 is Low.

More complex signal filters can be made by filtering on several channels or by setting up a so-called Signal Filter Delay. As noted above, be aware that if the filter conditions cannot be met, no data is stored. See the setup dialog box in Figure 4-28. Click Cancel in this dialog box to return to regular conditions.

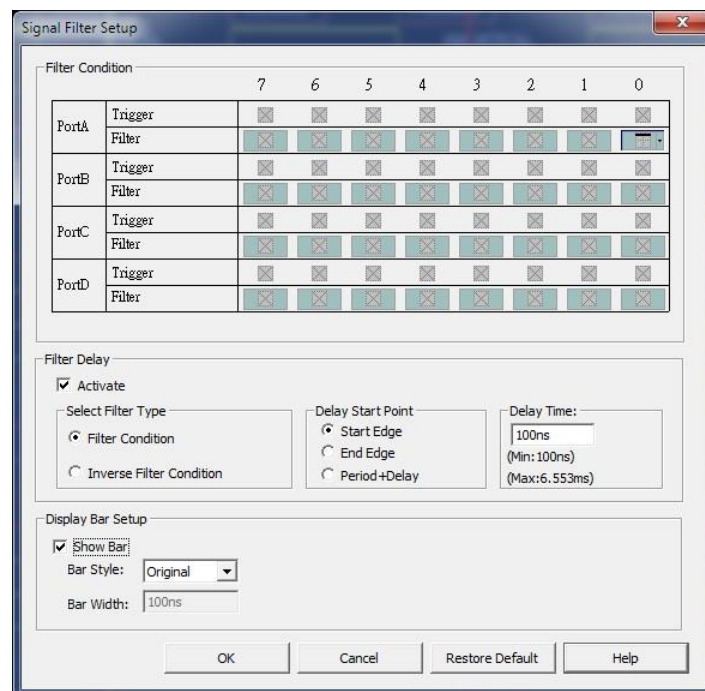

Figure 4-28 Signal Filter dialog box

Item	Description
------	-------------



Checkboxes	Click to set filter condition for one or more channels.
Select Filter type	
Filter Condition	Filter on the checked conditions: <ul style="list-style-type: none">– Indifferent means that the LAP-C captures all signals from sampling. This is the default setting.– High Level means that the LAP-C captures and displays input signals that satisfy the high level condition.– Low Level means that the LAP-C captures and displays input signals that satisfy the low level condition.
Inverse Condition	Filter on the opposite of the checked conditions.
Delay Start Point	See graphical descriptions of how these are defined in Figures Figure 4-29 to Figure 4-31.
Delay Time	To use with the final alternative of the Delay Start Point.
Display Bar	
Bar Style	Know the length of signals that are filtered away; see Figure 4-34.
Bar Width	The bar width can be user-defined and it ranges from 1 to 65,535 sample points.

Table 4:15 Signal Filter dialog box description

There are three start point configurations available for delays as seen below:

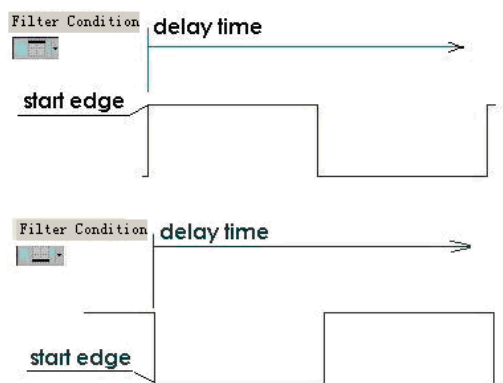

Figure 4-29 Signal Filter / Delay Start Point – Start Edge

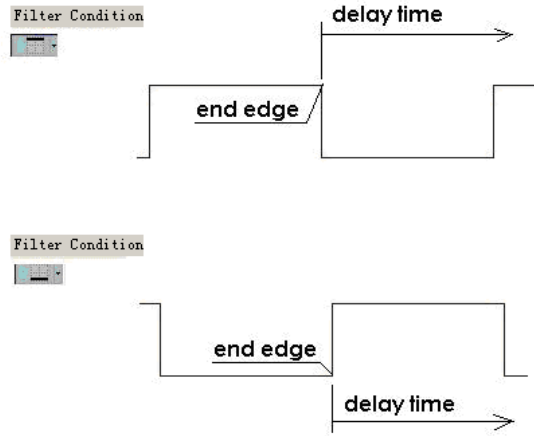

Figure 4-30 Signal Filter / Delay Start Point – End Edge

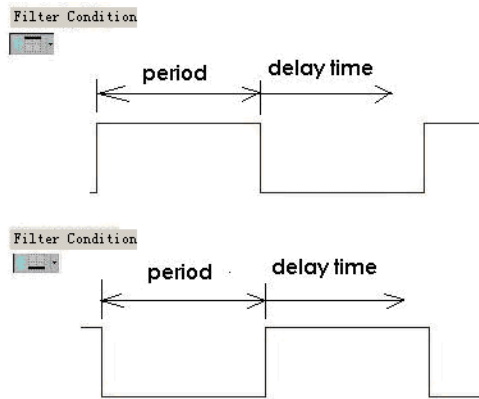

Figure 4-31 Signal Filter / Delay Start Point – Period + Delay

After a filter condition has been set, only qualified signals will be shown. This is exemplified in Figure 4-32 and Figure 4-33. In the latter, a high filter has been added to channel A1.

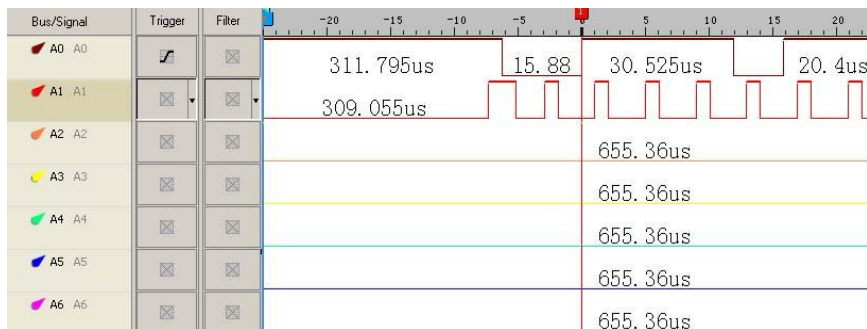

Figure 4-32 Signal Filter example / Pre-filter signal

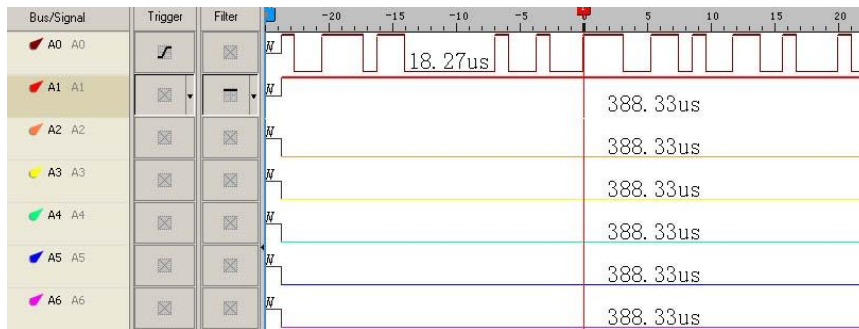

Figure 4-33 Signal Filter example / Post-filter signal with A1 filter = High

See an example of the bar in Figure 4-34.

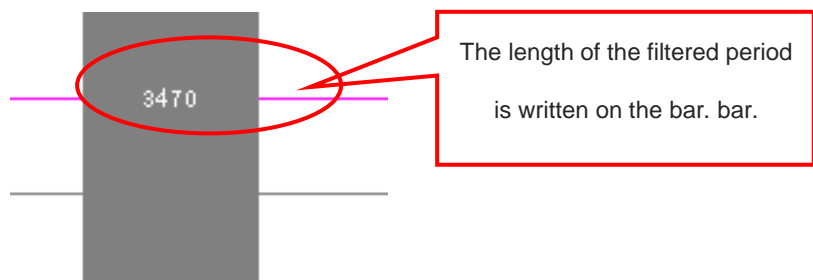

Figure 4-34 Signal Filter – Bar with length annotation



If no results are displayed, it could be that the Filter conditions are too rigorous. To find out if this is the case, click Stop and try to lax the conditions.



The Signal Filter Delay is incompatible with the Compression and Double Mode functions due to signal quality and memory concerns. Also, the time interval between two signal filters must be more than two clocks.

4.22. Trigger Setup – Channel

Trigger Setup – Channel is used to define a trigger condition for a single channel. The LAP-C will trigger on the first event that satisfies the conditions. See the dialog box in Figure 4-35.

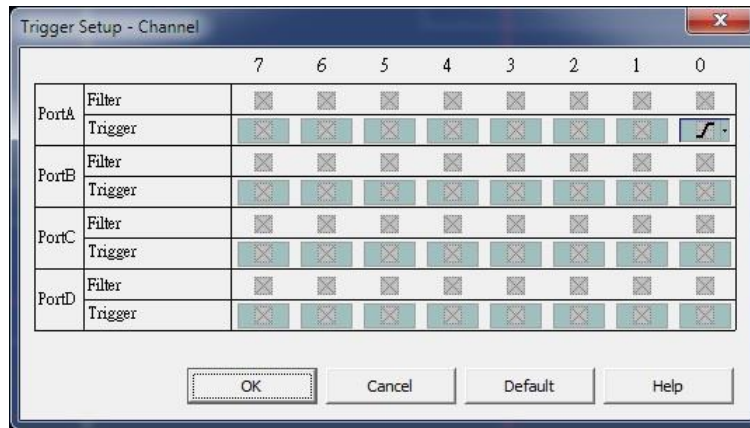

Figure 4-35 Channel Trigger Setup dialog box



If it proves difficult to find the desired event by means of the Trigger Setup – Channel, try to make the condition it more specific using the Trigger Properties of chapter 4.24.



In the trigger column, left-click or hit space to change the trigger condition of the selected channel.

4.23. Trigger Setup – Bus

After creating and selecting a bus, the Trigger Setup – Bus becomes available. From this dialog box users can trigger on bus and packet values; see Figure 4-36 below.

Note that it is also possible to enter the dialog box by right-clicking on a bus in the trigger column.



Enter the Protocol Decoder Trigger setup from this dialog box; as seen in Figure 4-38. The function is described further down in this subchapter.

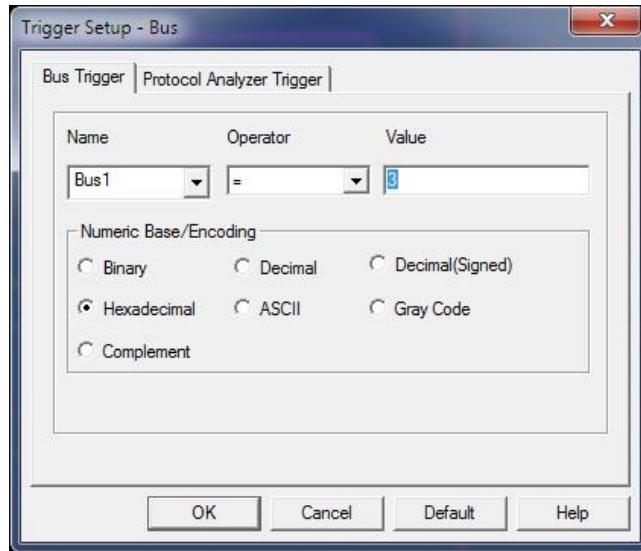

Figure 4-36 Bus Trigger Setup dialog box

Item	Description
Bus Name	Select bus.
Operator	Select operator.
Value	Select desired trigger value.
Numeric Base/Encoding	Choose how data should be displayed; see chapter 4.41.

Table 4:16 Bus Trigger Setup dialog box description

Figure 4-37 shows an example of the bus trigger. The condition is a hexadecimal value equal to 2. It is clear from the red trigger bar in the waveform in the background that when running the acquisition the LAP-C triggers on 0X0.

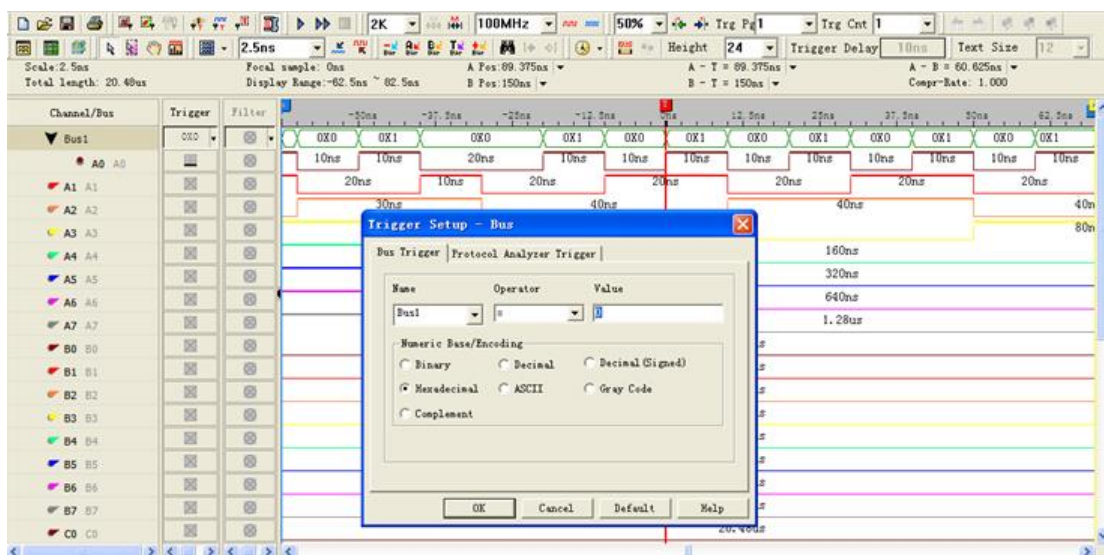

Figure 4-37 Bus Trigger example

The Protocol Trigger function of the LAP-C is helpful for users who want to locate a particular element of a protocol. The function is implemented in the software, its setup varies from protocol to protocol, and it works as follows: After acquisition, the software looks for a pattern in the acquired data that satisfied that packet trigger condition. If the condition is not found, a new capture is initiated. The process is repeated until the desired data is found.



This function comes for free with the LAP-C322000 model. For all other models it is an optional purchased.

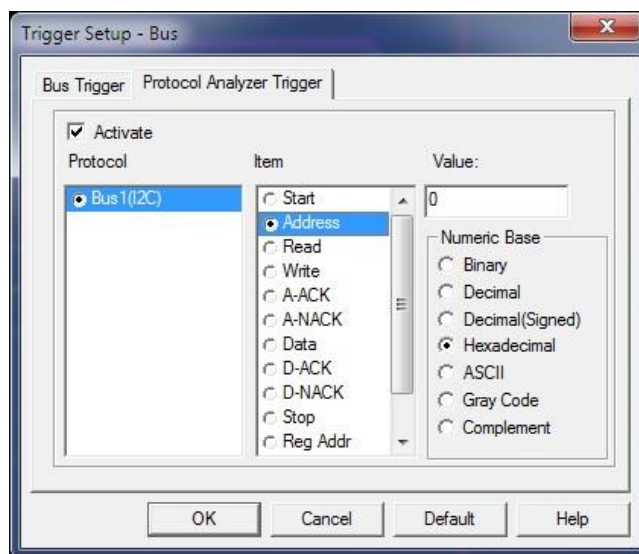

Figure 4-38 Protocol Decoder Trigger dialog box

Item	Description
Activate	Enable the Protocol Decoder Trigger function.
Protocol Decoder	Select desired protocol decoder. Note that this must first be added to the bus as explained in chapter 4.18.
Protocol Packet	The available packets and events depend on the chosen protocol.
Value	The value input is only activated for certain packet types such as DATA. For START and similar it is unavailable. Again, this depends on the protocol in question.
Numeric Base	Choose how data should be displayed; see chapter 4.41.

Table 4:17 Protocol Decoder Trigger dialog box description



Figure 4-39 shows an example of the Protocol Decoder Trigger. The LAP-C triggers on a 70 data value in an I2C protocol as seen from the dialog box and the red trigger bar in the background.

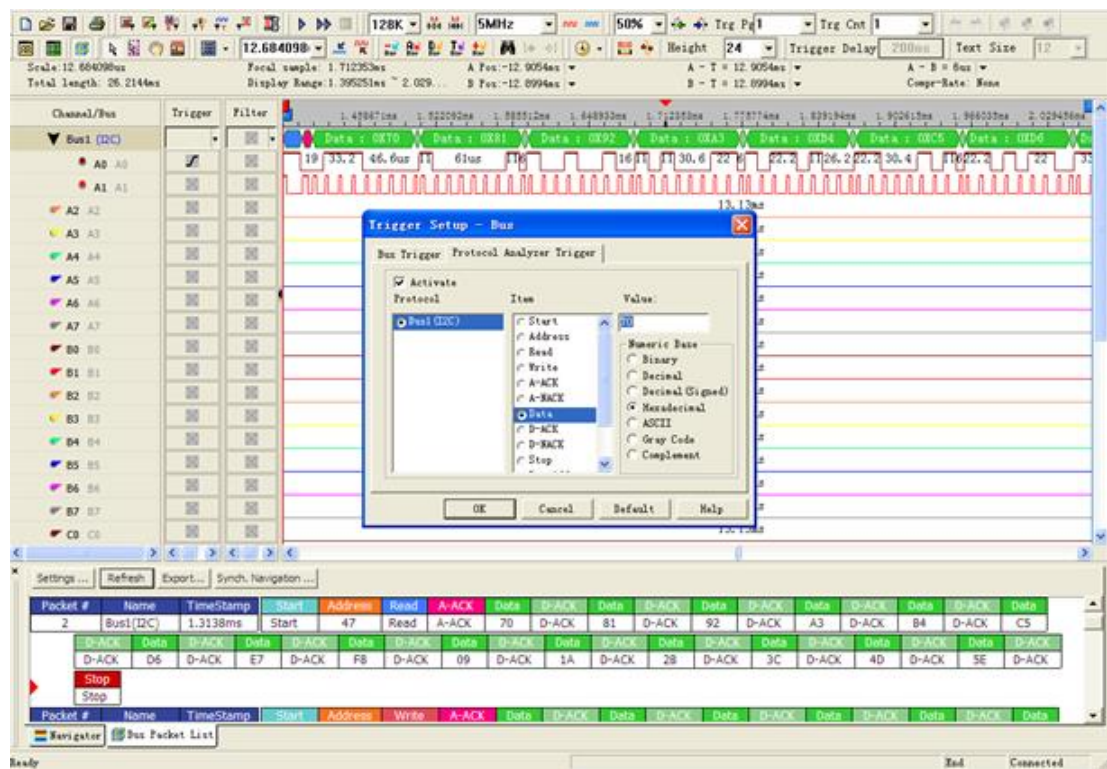

Figure 4-39 Protocol Decoder Trigger example

4.24. Trigger Properties

The Trigger Properties dialog box comprises the following trigger features: Trigger Level, Trigger Count, Trigger Page, Trigger Delay and Repeated Triggering. These are treated one by one in the subchapters below.

4.24.1. Trigger Settings

The Trigger Voltage defines when a signal changes state. In other words; if the voltage of a signal is inferior to the Trigger Voltage it will be regarded as 0 (Low), and vice versa. Similarly, when the signal voltage rises from below to above the Trigger Voltage, the LAP-C will consider that a change of state from Low to High has occurred and that the new state is 1 (High). The Trigger Voltage is sometimes referred to as



Trigger Level or Threshold Level.

The LAP-C lets users use up to 4 different Trigger Levels at a time; one for each of the four ports A, B, C and D. For each level, four pre-defined levels are available: TTL, CMOS (5 V), CMOS (3.3 V) and ECL. It is also possible to user-define the Trigger Level. See the dialog box in Figure 4-40. The permitted voltage range is +6 to -6V.



This dialog box also holds the Trigger Mark function. A description is given below Figure 4-40.

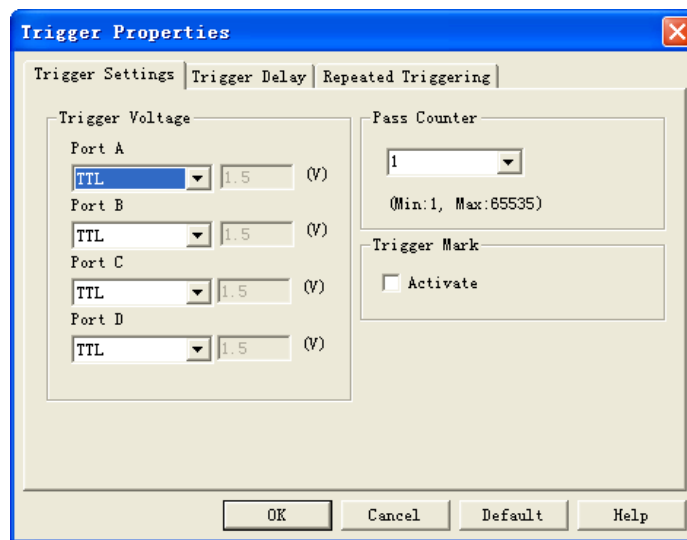

Figure 4-40 Trigger Properties dialog box

Activate the Trigger Mark function to place cursors on all samples that meet the trigger conditions, not just the first one occurrence (which always has the T-bar). By default, only one trigger bar is shown (the T-bar), but there can be up to 128 trigger bars. These are named T0, T1, T2 etc and they are all red. Trigger Marks are sometimes referred to as Cursors or Auxiliary Cursors. Figure 4-41 shows an example of the Trigger Marks activated with an I2C bus and trigger condition Data=0.

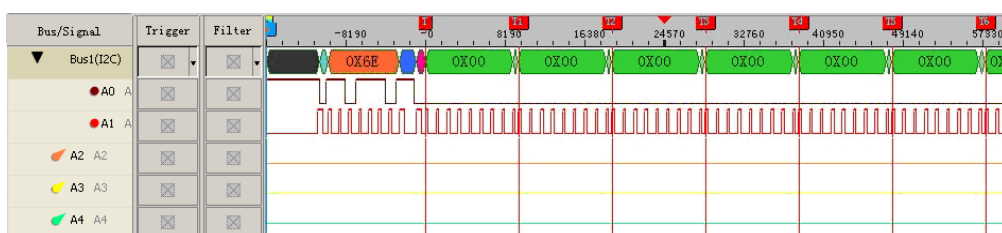

Figure 4-41 Protocol Analyzer Trigger Mark



The Trigger Mark function is included in the LAP-C162000 and LAP-C322000 models. It must be purchased separately for the LAP-C16032, LAP-C16064, LAP-C16128, LAP-C32128 and LAP-C321000 models.

4.24.2. Trigger Count

By default, the LAP-C will trigger on the 1st occurrence of the trigger event. With the Trigger Count, users can instead choose to trigger on the Xth event that satisfies the trigger conditions. Trigger Count is sometimes called Trigger Pass Counter.

Figure 4-42 shows an example where the Trigger Count is set to 5 (as seen in the upper, rightmost drop-down list). The red trigger bar is located at the 5th occurrence of a rising edge on channel A0.

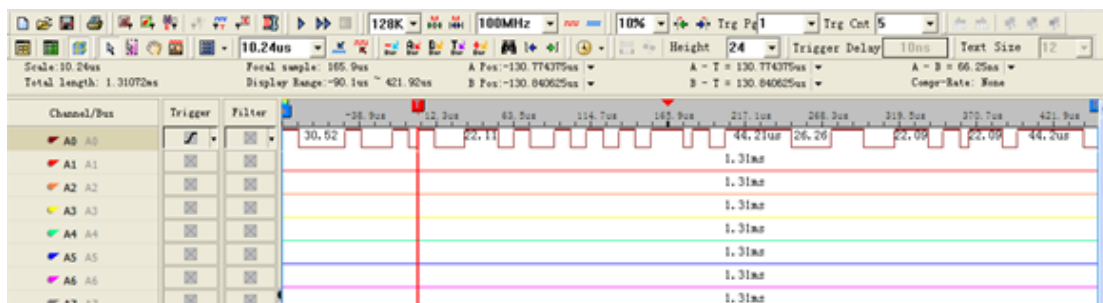

Figure 4-42 Trigger Count example



To have the LAP-C trigger on the 1st trigger event, simply set the Trigger Count to 1.

4.24.3. Trigger Delay

Trigger Delay means that the LAP-C starts to store data a certain time after the occurrence of the trigger event. The exact length is user-defined in the Memory Delay or Timing Delay field; see the dialog box in Figure 4-43.

The Memory Delay refers to the depth of the acquisition. If the memory depth is set to 32 kb and the multiplier is set to 10, the LAP-C will start to store samples after 320 kb of data has been transmitted following the trigger event.



Timing Delay is useful for those who would rather define the delay in terms of absolute time or a number of clock cycles. As with the Memory Delay, the LAP-C will trigger after a certain amount of seconds or a certain number of clock cycles have passed following the trigger event.

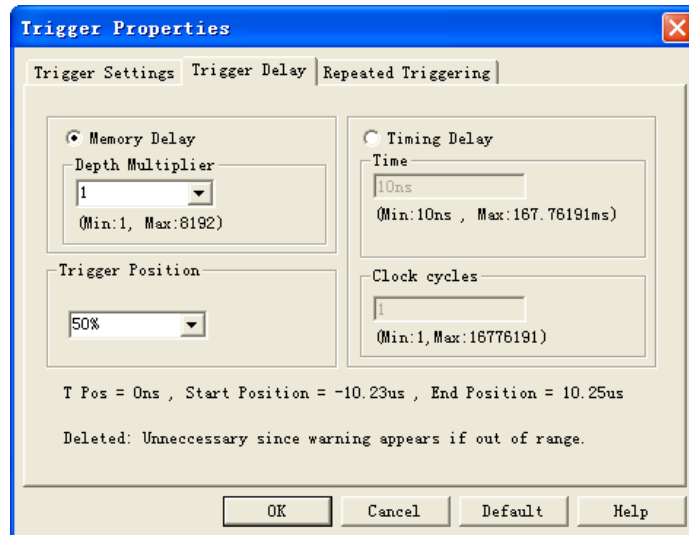





Figure 4-43 Trigger Delay dialog box

-  The trigger bar (T-bar) will not be displayed when the setup of the Memory Delay is more than 1 (since the trigger event is located before/outside the acquired data).
-  The delay length in Timing Delay mode is calculated as the Time in Timing Delay divided by the Acquisition Rate.
-  Timing Delay is unavailable in Compression mode.

4.24.4. Trigger Position

The Trigger Position (also referred to as Pre/Post Triggering) determines which samples are stored. At the default 10%, 10% of the available memory is allocated to pre-trigger data and 90% to post-trigger data. The Pre/Post ratio can be adjusted freely: Users who want to see more of what happens prior to the trigger event can set a high ratio; likewise, users who want to see what happens in the wake of the trigger event can set a low ratio. Trigger Position is sometimes called Pre/Post Triggering.



Figure 4-44 and Figure 4-45 show examples of how the Trigger Position works. In the top figure, the Trigger Position is set to 0% which means that the red T-bar is located at the beginning of the acquisition. In the lower figure the position is 10%, meaning that the LAP-C will also show some data leading up to the trigger event.

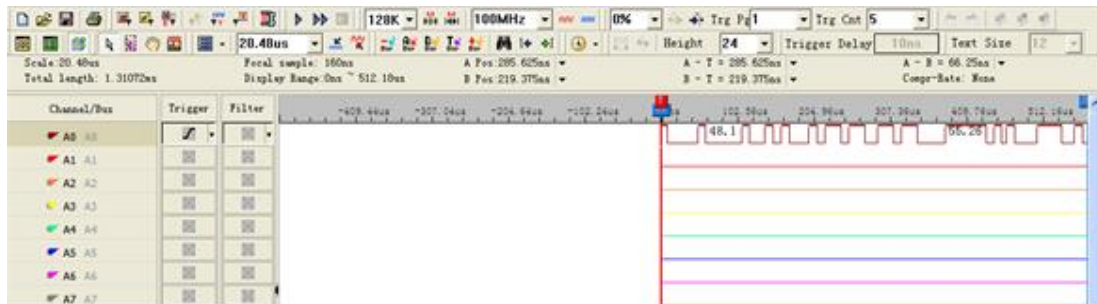

Figure 4-44 Trigger Position example – 0%

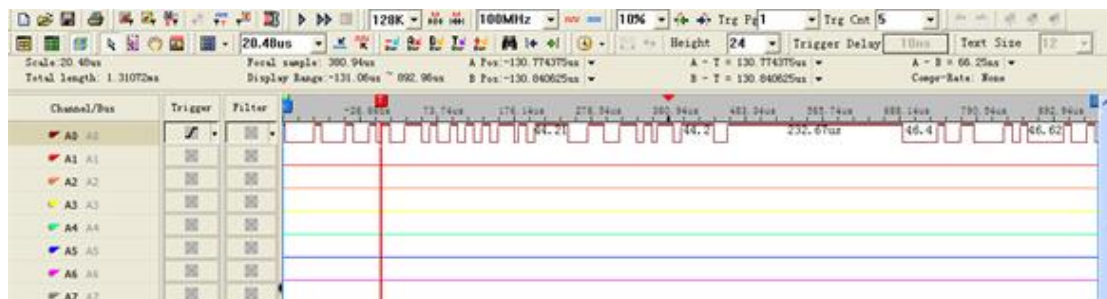

Figure 4-45 Trigger Position example – 10%

4.24.5. Repeated Triggering

Repeated Capture is used to restart acquisitions periodically until a Stop Condition is met. The Stop Condition can either be a function of the number of triggers (trigger X times then stop) or of time (trigger periodically for X seconds then stop); see the dialog box in Figure 4-46. The Repeated Triggering can be useful in the elaboration of tests or statistics, or to limit the number of output files during repeated captures.

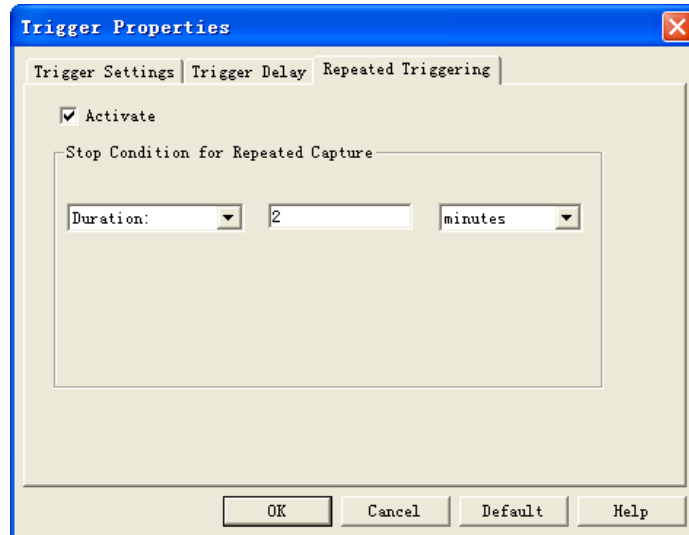

Figure 4-46 Repeated Triggering dialog box

4.25. Pulse Width Trigger Module

The Pulse Width (PW) Trigger Module adds PW triggering ability to the LAP-C. This type of triggering can be very powerful; indeed PW triggering is the most convenient and popular way to find cycles of a particular length in a signal. Three trigger conditions are possible: the width between two falling edges, two rising edges, or the width of a complete cycle. Please refer to the specification sheet of the PW Trigger Module for more details.



The PW Trigger Module is included in the purchase when buying the LAP-C 322000 model. For other LAP-C models it is available as an additional accessory.

4.26. Connect Multiple LAP-Cs

It is possible to stack up to 4 LAP-Cs of the same model to increase the memory depth or channel count. Using two 16 channel logic analyzers with 2 Mb memory the user can achieve one of the following two configurations depending on their preference:

- Channel Mode: 32 channel sampling with 2 Mb memory depth.
- Memory Mode: 16 channel sampling with 4 Mb memory depth.



In other words, it is possible to reach a maximum of $32 \times 4 = 128$ channels, and likewise for memory. Note that this function only works with identical LAP-C models.



This is a software function and the instruments work independently, though they are synchronized.

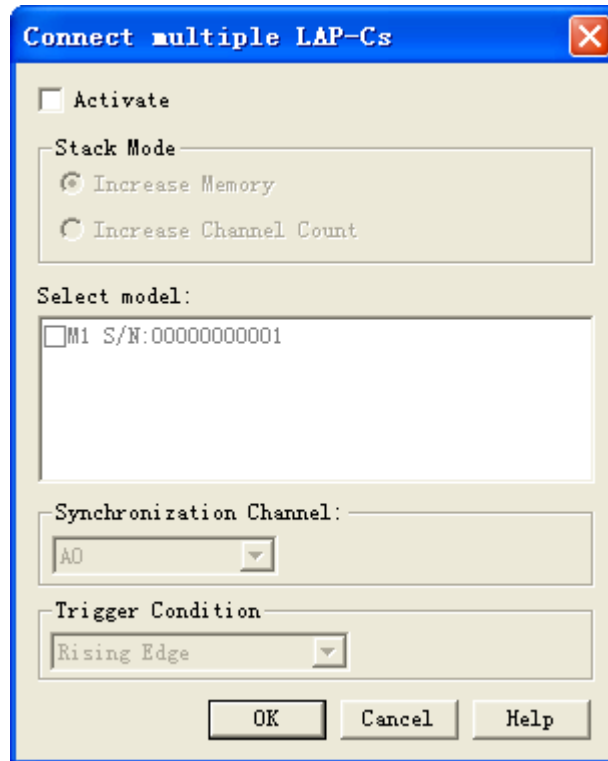

Figure 4-47 Connect Multiple LAP-Cs dialog box

Item	Description
Activate	Check to activate the function.
Stack Mode	Stack memory or channels.
Select model	The serial numbers of all connected LAP-Cs are shown, with M1 being the 1 st LAP-C, M2 the 2 nd etc. Select from 2 to 4 instruments.
Synchronization Channel	Select channel on which to base synchronization of the acquisitions; the default is A0.
Trigger Condition	Select the synchronous trigger condition. This is only for use in Channel Mode.

Table 4:18 Connect Multiple LAP-Cs dialog box description

Figure 4-48 shows an example of the Memory Mode stack. Two LAP-Cs are



connected with A0 as the synchronous channel (as seen in the Trigger Column). The data to the left of the yellow A-bar is captured by the first LAP-C, the data to the right by the second.

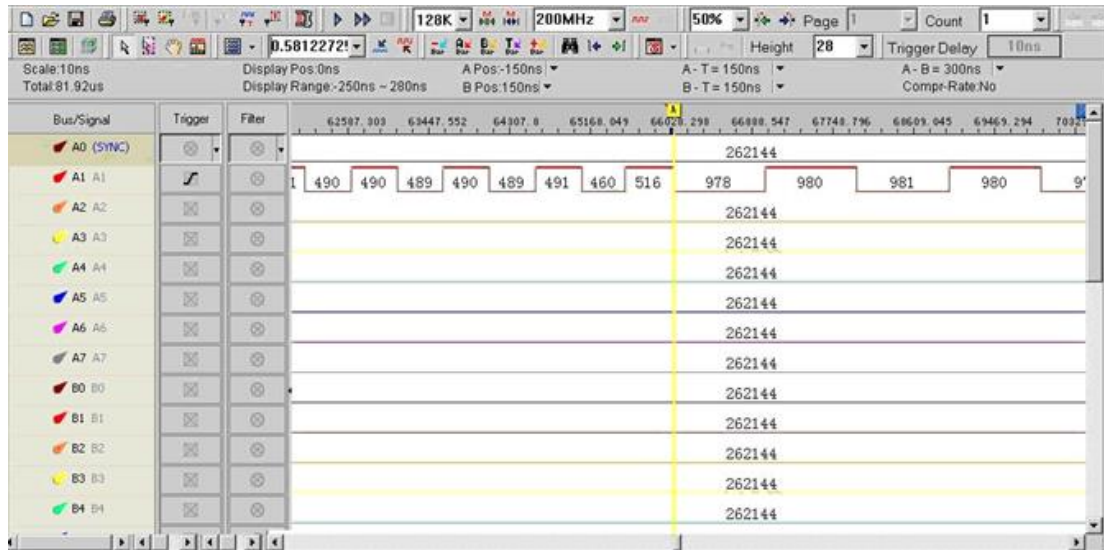

Figure 4-48 Stack LAP-Cs – Memory Mode example



If two LAP-Cs are connected but the software only displays signal from one of them, it could be that you are using a model that does not support this function (see below) or that the probes, ground or power has not been properly connected. See chapter 2.2 for instructions on how to connect the hardware.



The Connect Multiple LAP-Cs function is available for the LAP-C32128, LAP-C321000 and LAP-C322000 models only. It is not available for the LAP-C16032, LAP-C16064, LAP-C16128 and LAP-C162000 models.

4.27. Connect to DSO

A DSO Connection can be set up when users want to import and display DSO signals in the LAP-C software. This can be useful since the LAP-C does not have the ability to capture analog signals. The supported DSO models are listed in Table 4:21.

Two operation modes are possible; the connection can be set up with the LAP-C as master or slave depending on which instrument the user wants to provide the trigger signal. The two modes are described in continuation. The settings are described in



chapter 4.27.3, an example is shown in chapter 4.27.4, and the available models are listed in chapter 4.27.5.

4.27.1. LAP-C as Master

When the LAP-C is master, the DSO is slave. In this mode, the Trigger OUT of the LAP-C connects with the Trigger IN of the DSO. When the trigger event occurs, the LAP-C sends a trigger signal to the DSO which, upon receiving the signal, starts to capture data. See the complete connection diagram in Figure 4-49.

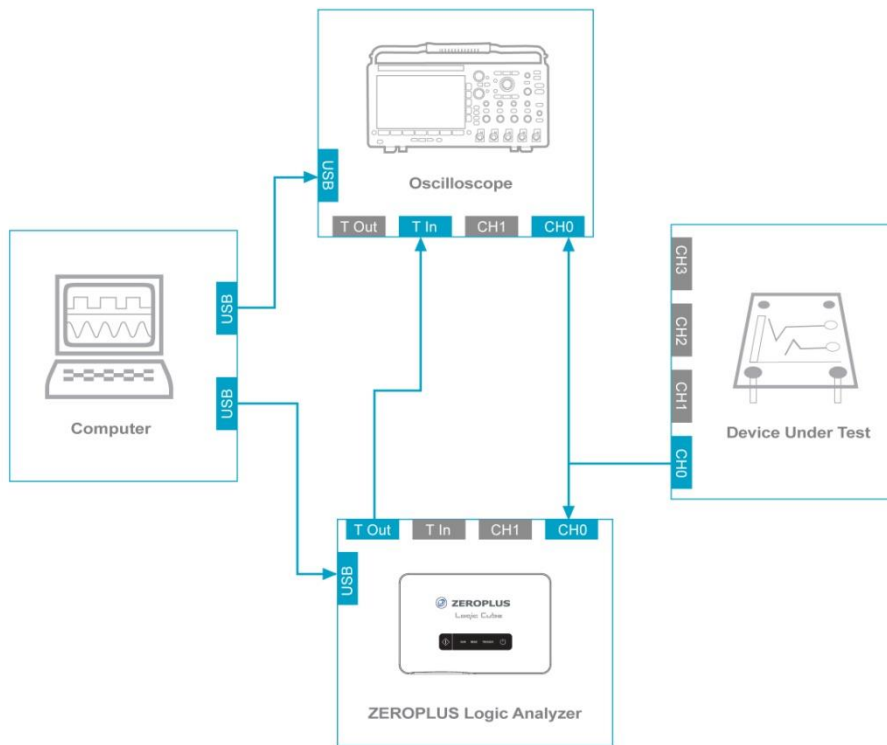

Figure 4-49 Connection diagram with LAP-C as Master

4.27.2. LAP-C as Slave

When the LAP-C is slave, the DSO is master. In this mode, the Trigger OUT of the DSO connects with any channel of the LAP-C. When the trigger event occurs, the DSO sends a trigger signal to the LAP-C which, upon receiving the signal, starts to store data. See the complete connection diagram in Figure 4-50.

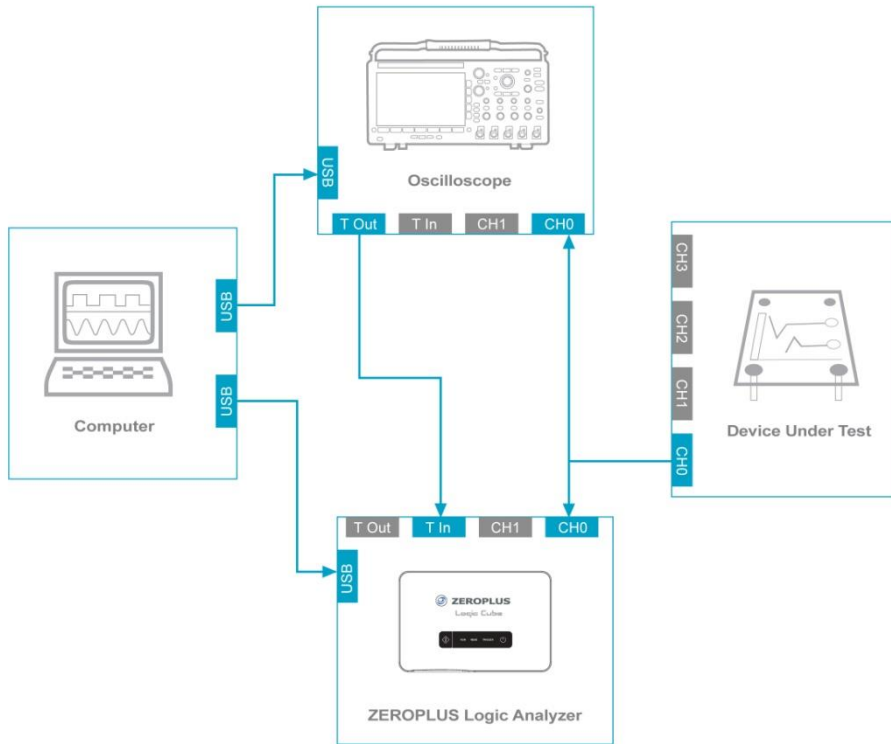

Figure 4-50 Connection diagram with LAP-C as Slave

4.27.3. Settings

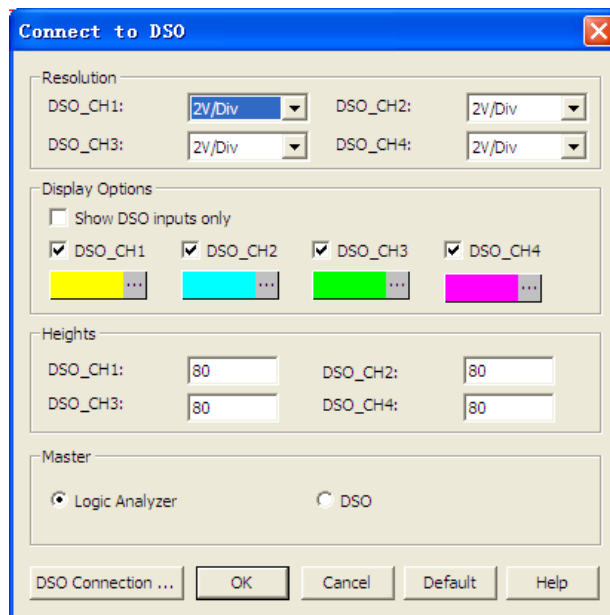

Figure 4-51 DSO Connection dialog box



Item	Description
Resolutions	
DSO_Ch1-4	Adjust the vertical resolution of the input signals ranging from 2mV/Division to 3V/Division in a total of 10 steps.
Display Options	
Show DSO inputs only	Do not display any of the regular signals.
DSO_Ch1-4	Choose which DSO signals to display in the waveform area, as well as their colors.
Heights	
DSO_Ch1-4	Set the trace height in pixels from 30-400; 80 is default.
Master	
Logic Analyzer	The LAP-C is master, the DSO slave. See chapter 4.27.1.
DSO	The LAP-C is slave, the DSO master. See chapter 4.27.2.
DSO Connection	Open the DSO Settings dialog box from Figure 4-52 below. The interface will depend on the DSO brand.

Table 4:19 DSO Connection dialog box description

The options is the dialog box from Figure 4-52 become available once a DSO has been connected and recognized by the LAP-C.

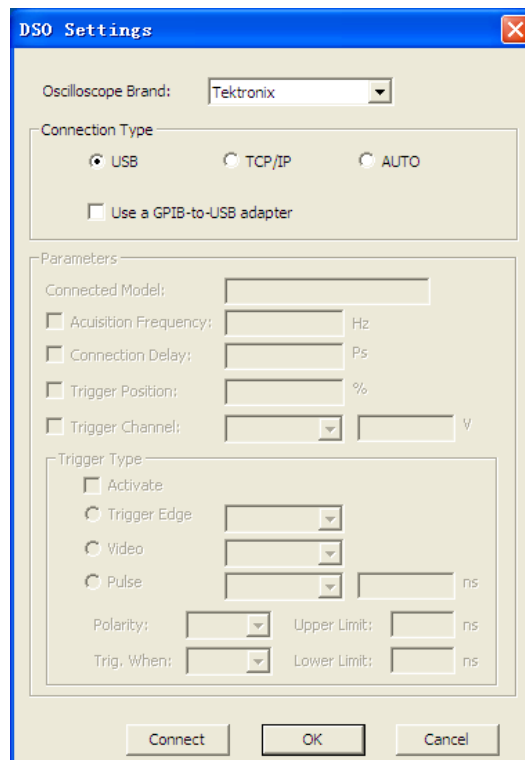

Figure 4-52 DSO Connection / Settings dialog box



Item	Description
Oscilloscope Brand	Select DSO brand to import signals from, then click Connect. None will be displayed if no oscilloscope is connected. See a list of all available brands in Table 4:21.
Connection Type	Make a selection in line with the DSO's connection to the PC. If selecting IP, it must be the same as the PC's. Users can also select Auto for auto-recognition.
Parameters	
Connected Model	Name of connected DSO.
Acquisition Frequency	Match the sampling speeds; ranging from 1/5ns to 1/50s.
Connection Delay	Align the trigger bars of the two instruments; the range is $\pm 1,000,000$ ps.
Trigger Position	Set the Trigger Position from 0-100%.
Trigger Channel	Trigger level range is -16 to +16V.
Trigger Type	Select trigger type among the drop-down alternatives.
Connect	Click to connect/disconnect to the DSO.

Table 4:20 DSO Connection Settings dialog box description

4.27.4. Result

Figure 4-53 shows an example of the DSO Connection function. Two DSO channels are displayed in the LAP-C software as seen by the purple and blue traces. Notice how this approach allows for considerably higher sample rate and better resolution than other PC based logic analyzers who have built-in analog channels with very low bandwidth.

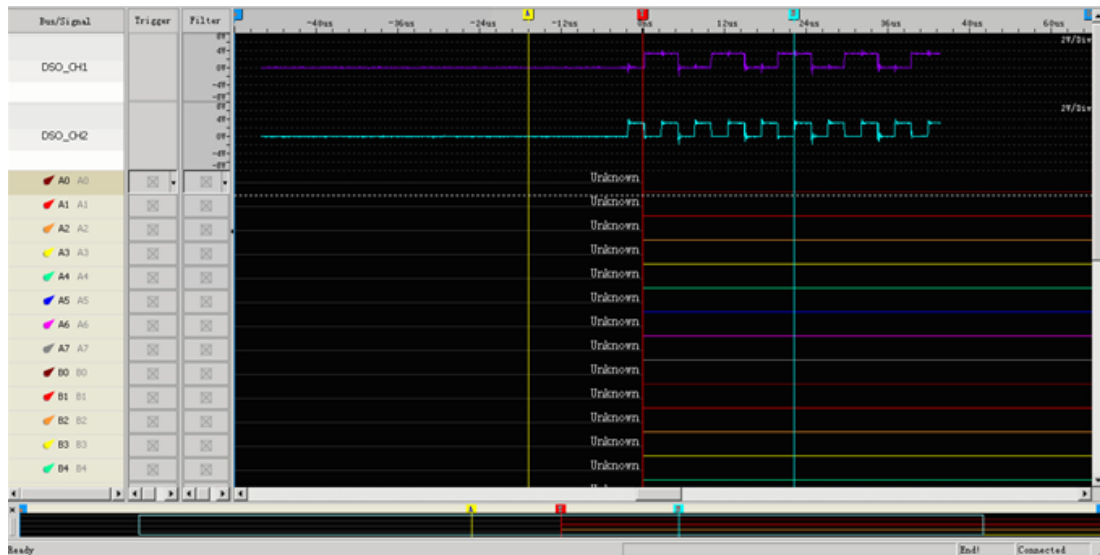

Figure 4-53 DSO Connection example – DSO signals imported

4.27.5. Supported DSO models

The supported DSO models are listed in Table 4:21.

Brand	Models	On-line Mode
Tektronix	TDS1000 Series	USB
	TDS2000 Series	USB
	TDS3000 Series	USB, TC/IP, GPIB
	TDS5000 Series	GPIB
	TDS6000 Series	In-built GPIB
OWON	SDS7102 Model	USB
PicoScope	3206B Series	USB
GwInstek	GDS-1000A Series	USB
	GDS-3000 Series	USB
Agilent	DSO5000 Series	USB
BK Precision	2540B, 2542B, 2540B-GEN, 2542B-GEN	USB

Table 4:21 Supported DSO models

To use the LAP-C with any of the DSOs listed above it is necessary to install software from the manufacturer; see Table 4:22 for details.

Brand	Driver	Website
Agilent	Windows USB Driver	www.chem.agilent.com



BK Precision	Windows USB Driver	http://www.bkprecision.com/
Gwinstek	Windows USB Driver	www.gwinstek.com
Owon	Windows USB driver	www.owon.com.cn
PICO	Windows USB driver	www.picotech.com
Tektronix	Tekvisa Connectivity Software V3.3.4	www.tektronix.com

Table 4:22 List of DSO drivers

4.28. Single Capture

Capture samples one time using the current acquisition settings and trigger conditions. The capture can also be started by pressing the START button at the top of the logic analyzer.

Hot Key: F5

4.29. Repeated Run

Repeated Capture is used to restart the acquisition periodically until a STOP is pressed or a Stop Condition is met. The Stop Condition can either be a function of number of triggers (trigger X times then stop) or of time (trigger periodically for X seconds then stop); see details in Figure 4-18.

Hot Key: F6

4.30. Stop

Stop an ongoing acquisition. The user can choose between two different software behaviors when pressing Stop:

- Show the previous (complete) acquisition
- Show the newly acquired data

Switch between the two alternatives in the Settings / General dialog box; see Figure 4-9.



If the LAP-C keeps waiting without initializing an acquisition, as shown in Figure 4-54, click STOP, then check the acquisition settings and trigger conditions, and try to capture again.

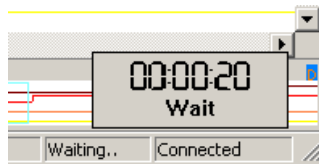

Figure 4-54 Waiting to acquire

4.31. Cumulative Packet Run

Cumulative Packet Run lets you keep the data from all runs when making repeated acquisitions. The default behavior of the LAP-C is to overwrite the packet data from the previous acquisition when sampling in Repeated Run mode. By using this function, this behavior can be overturned: When the acquisition has finished, the Packet List will show the packets from first run at the top of the list, followed by the packets from second run etc up until the number of runs.

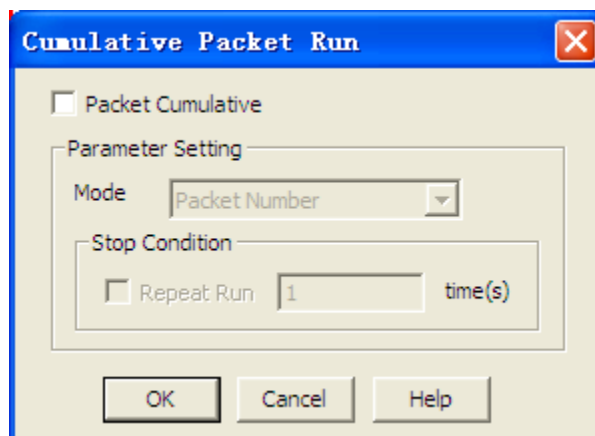

Figure 4-55 Cumulative Packet Run dialog box

Item	Description
Packet Cumulative	Activate the function.
Mode	Select Packet Result to display all acquired packets or Packet Number to show the packets final acquired.
Stop Condition	Stop acquiring after a certain number of times.

Table 4:23 Cumulative Packet Run dialog box description

Trigger#	Packet #	Name	TimeStamp	Data	Length
T1	1	Bus1(Bus)	0ns	0	1.025ms
Trigger#	Packet #	Name	TimeStamp	Data	Length
T2	2	Bus1(Bus)	0ns	0	1.025ms
Trigger#	Packet #	Name	TimeStamp	Data	Length
T3	3	Bus1(Bus)	0ns	0	1.025ms
Trigger#	Packet #	Name	TimeStamp	Data	Length
T4	4	Bus1(Bus)	0ns	0	1.025ms

Figure 4-56 Cumulative Packet Run window example

Analysis

4.32. Menu Layout

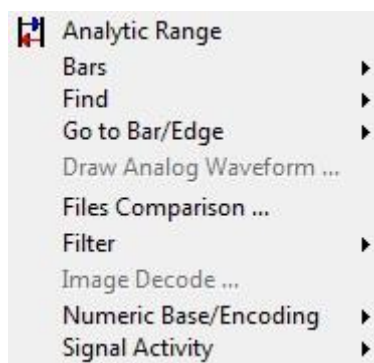
Figure 4-57 Analysis drop-down menu

4.33. Analytic Range

Change the analysis range by adjusting the position of the so-called Ds and Dp bars. The Ds-bar marks the beginning of the Analytic Range and the Dp-bar marks the end. The Analytic Range can be used to reduce the size of acquisitions by hiding parts of the acquired data. This can be useful for navigation, reducing file sizes etc. These bars are locked whenever the user has not entered the Analytic Range.



Adjusting the Analytic Range will hide – not delete – data.

4.34. Bars

The LAP-C software Waveform and State List areas come with 5 standard bars (these are sometimes referred to as Cursors). The bars delimit the analysis range and facilitate navigation and observation. The five standard bars are described in Table 4:24.

Bar	Description
Ds bar	Demarks the beginning of the buffer data area; use the Analytic Range function to adjust its position.
Dp bar	Demarks the end of the buffer data area; use the Analytic Range function to adjust its position.
T-bar	The T-bar marks the trigger event. Press T to center the waveform view on the T-bar.
A-bar	Default bar intended for navigation and measurement that the user can move freely. Press A to center the waveform view on the A-bar.
B-bar	Default bar intended for navigation and measurement that the user can move freely. Press B to center the waveform view on the B-bar.

Table 4:24 Description of the five standard bars



Navigate quickly to a bar by pressing the bar name on the keyboard (A, B or T).

4.34.1. Add

Users can insert up to 250 additional bars. When adding a bar the user can select color and where it should be positioned (in time). The bars will automatically be named A0-A9, B0-B9 etc.

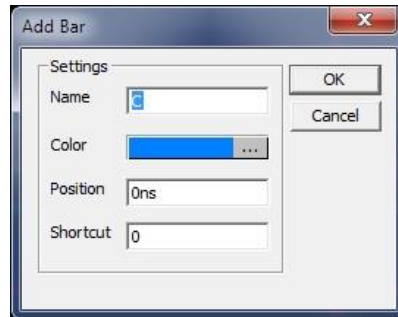

Figure 4-58 Add Bar dialog box



Bars can also be added by right-clicking in the waveform.

4.34.2. Delete

Open the delete bar dialog box and select the bar that is to be deleted.



Only user-defined bars can be deleted.

4.35. Find

4.35.1. Data Value

The Find Data Value dialog box serves both channels and buses. If selecting a signal, the Find function can be used to locate edges or high/low states within the whole data set or between two bars of choice. A bar is placed on the event that satisfies the search conditions.

When considering buses, the Find Data Value is used to search for a specific data value within the acquired samples. See the interface of this dialog box in Figure 4-59.

Note that to enable this function a bus must be created first.



The Find Data Value function has memory: When reopening the dialog box after closure the last search conditions are shown.



It is also possible to search for protocol addresses etc. This functionality is accessed by enabling the “Find a Sequence of Data” checkbox in Figure 4-59. Go to Figure 4-62

further down in this subchapter to read more about this function.

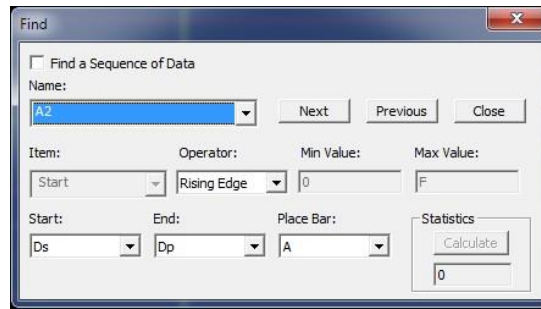

Figure 4-59 Find Data Value dialog box

Item	Description
Activate	Click to search for data sequences or packets. The interface will change from that of Figure 4-59 to that of Figure 4-62.
Name	Select which signal or bus to search in.
Next	Find the next event that meets the find condition.
Previous	Find the previous event that meets the find condition.
Close	Close the search.
Item	Select the bus component that is to be found.
Operator	For channel searches the event is either an edge (Rising, Falling, Either) or a High or Low state. Bus searches are based on values and ranges that are entered to the right.
Min/Max Value	For bus value or range searches.
Start/End At	Use bars to delimit the search range.
Place Bar	Place a bar at events that meets the find condition.
Statistics	Calculate the number of events that satisfy the search query.

Table 4:25 Find Data Value dialog box description

Figure 4-61 shows an example of the search result for an SIP protocol. The B-bar is placed at the beginning of 0X12 since it's the first data that supersedes the minimum value of 8.

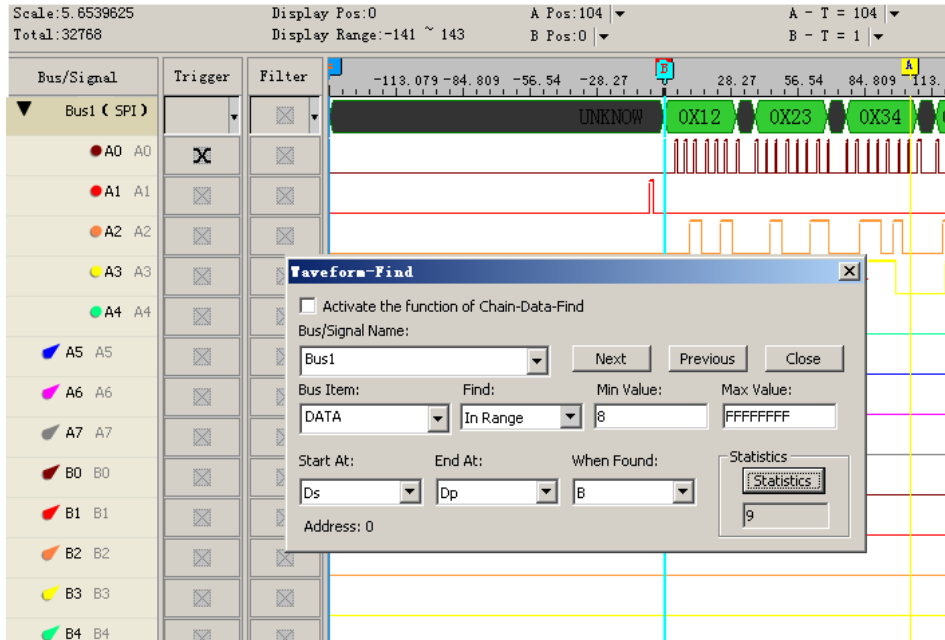

Figure 4-60 Find example: B-bar seen at start of SPI data 0X12

Note that for bus searches, the available bus items depend on the particularities of the bus' protocol. An example of the difference between the I2C and UART search alternatives is shown in Figure 4-61.

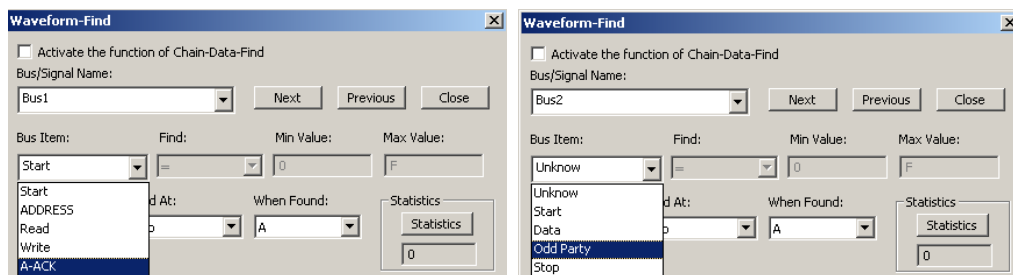

Figure 4-61 Find Data Value dialog box / I2C (left) versus UART (right)

As Figure 4-62 shows, the Find dialog box interface from Figure 4-59 changes when the “Find a Sequence of Data” is checked. Use this function to search for data in serial bus packets by specifying data values, addresses or similar.

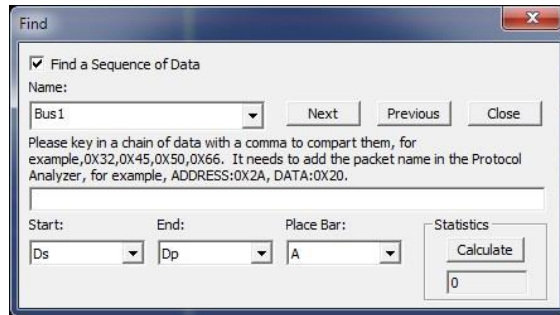

Figure 4-62 Find a Sequence of Data dialog box interface

4.35.2. Pulse Width

Use a pulse width (PW) definition to find an event. Figure 4-63 shows the dialog box.

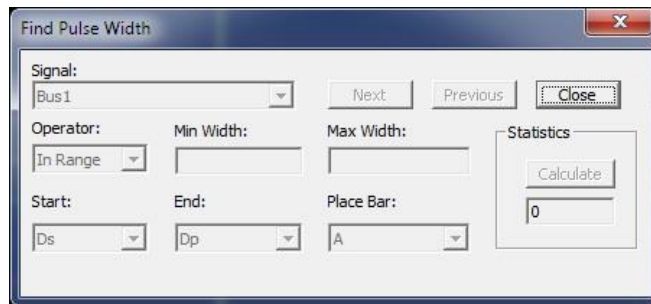

Figure 4-63 Find Pulse Width dialog box

Item	Description
Signal	Select where to search; the PW search does not work with buses.
Next	Find the next PW that meets the find condition.
Previous	Find the previous PW that meets the find condition.
Close	Close the search box.
Operator	Select operator.
Min/Max PW	Used with the find operator to specify the find condition.
Start/End At	Use bars to delimit the search range.
When Found	Place a bar at PWs that meets the find condition.
Statistics	Calculate the number of PWs that satisfy the search query.

Table 4:26 Find Pulse Width dialog box description

Figure 4-64 shows an example of how the PW Find works. The A-bar is placed on the first occurrence of a 20 ns long pulse on channel A1, as seen in the dialog box and the



waveform.

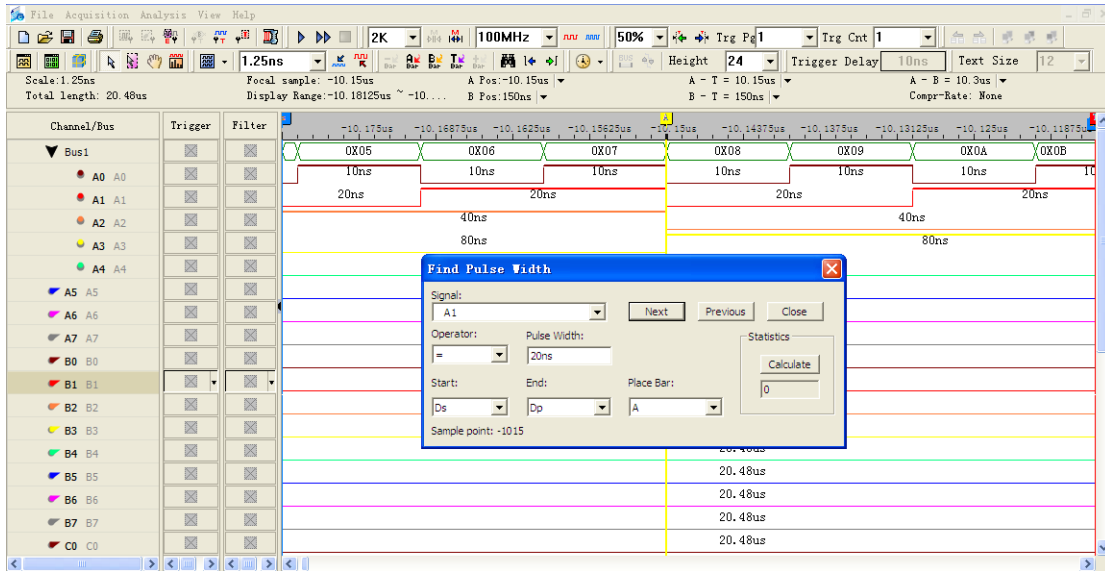

Figure 4-64 Find Pulse Width example

4.36. Go to Bar/Edge

The Go To function is used to find and navigate to a bar. Note that the waveform view shifts focus to the location of the bar/edge (as opposed to reposition the bar to where the user originally looks).

4.36.1. T-bar

Center the waveform on the A-bar.

Hot Key: T

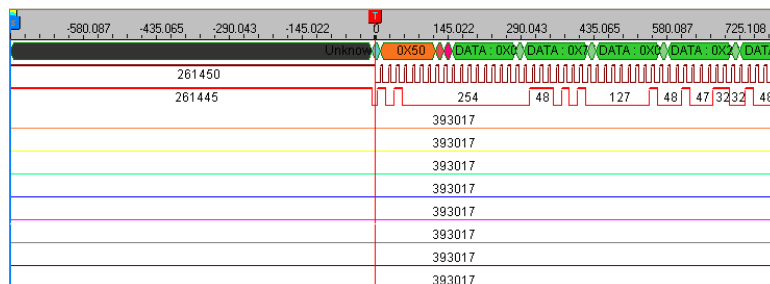

Figure 4-65 Go To example: Center the display around the T-bar



4.36.2. A-bar

Center the waveform on the A-bar.

Hot Key: A

4.36.3. B-bar

Center the waveform on the B-bar.

Hot Key: B

4.36.4. Another Bar

Center the waveform on a user-defined bar.

4.36.5. Previous Edge

Navigate to the previous edge.

Hot Key: F11

4.36.6. Next Edge

Navigate to the next edge.

Hot Key: F12

4.37. Draw Analog Waveform

The Draw Analog Waveform function is used to plot traces based on the value of bus data. It is especially useful for data that can be conveniently displayed visually, such as an ADC output represented by a sine wave. The function is available for simple buses (no packets). See the dialog box in Figure 4-66.

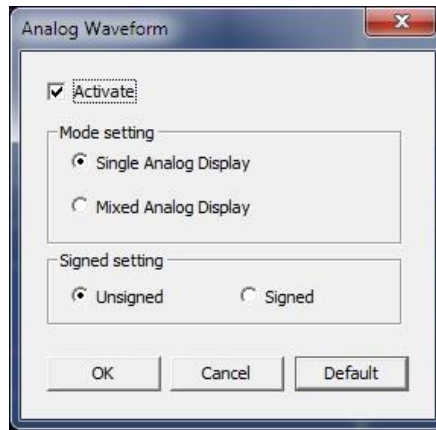

Figure 4-66 Draw Analog Waveform dialog box

Item	Description
Mode Setting	
Single Display	Don't show traces that constitute the waveform; see Figure 4-67.
Mixed Display	Show traces that constitute the waveform; see Figure 4-68.
Signed Setting	
Unsigned	Select unsigned data format for decimal numbers.
Signed	Select signed data format for decimal numbers.

Table 4:27 Draw Analog Waveform dialog box description

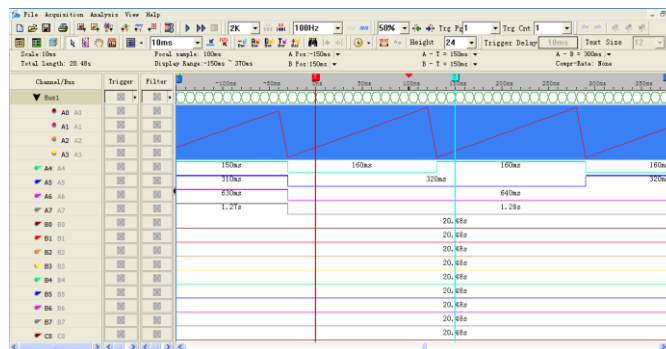

Figure 4-67 Draw Analog Waveform – Single Display

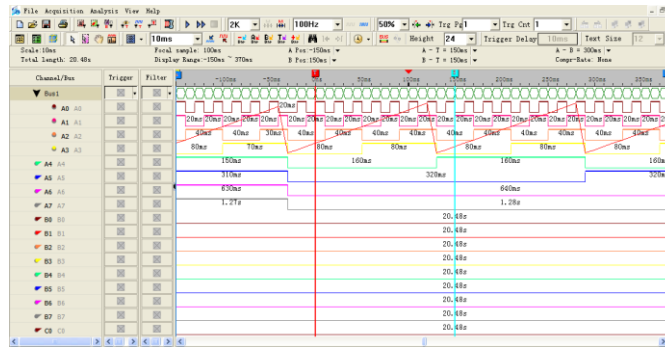

Figure 4-68 Draw Analog Waveform – Mixed Display



Note that this function only activates when the user selects a bus containing a minimum of four channels.

4.38. Files Comparison

Files Comparison examines how and where two files differ from each other. The number of differences between the two files is listed channel by channel in the dialog box. Also, new, curly traces in the waveform area evidence where the two signals differ; see an example in Figure 4-70.

Figure 4-69 shows the Files Comparison dialog box and the result of a data comparison of two files in table format. The number of differences between file 1 and file 2 are zero, meaning that the two files are identical.

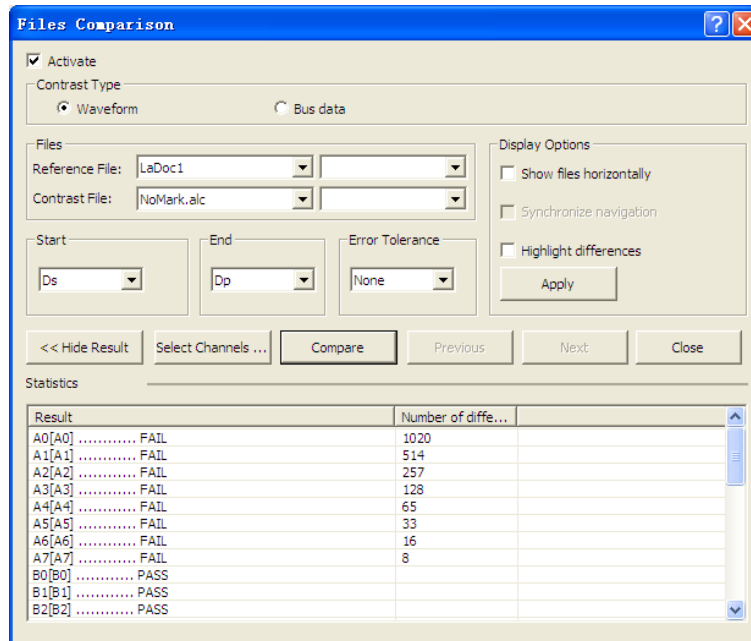

Figure 4-69 Files Comparison dialog box

Item	Description
Contrast Type	
Waveform	Contrast two waveforms.
Bus Data	Contrast the values of two buses and highlight the differences.
Select Files	
Reference File	Select a file. Note that only open files can be chosen.
Contrast File	Select the file that is to be compared to the Reference File. When contrasting with None, the Reference File settings will be used to make an acquisition.
Settings	
Start	Select where to start the comparison, using the Ref. file as base.
End	Select where to end the comparison, using the Ref. file as base.
Error Tolerance	Define how many sample points that may differ between the two files before the software regards the two files as unequal; 0-10 samples can be chosen (the default is 0).
Display Options	
Show files horizontally	Display the two files horizontally; unchecked by default.
Synchronize navigation	Synchronize panning across the two files.
Highlight differences	Mark the different waveforms with orange wavy lines.



Apply	Make changes effective.
Hide Results	Hide or unhide the Results area.
Select Channels	Select the channels to be contrasted. At least one must be chosen; by default all are selected.
Execute	Perform the Files Comparison.

Statistics

Results	Display the status of the comparison, PASS means the data in the channel is identical for the two files and FAIL means the data is different.
# of differences	The column shows the number of differences between the two files for each channel.

Navigation

Previous	Go to the previous difference between the two files.
Next	Go to the next difference between the two files.

Table 4:28 Files Comparison dialog box description

The reference file and the contrast file are displayed horizontally in the waveform area. New, orange, wavy traces ~~~~~, one per channel, show where the two files differ. The orange waves marking the differences can be discerned in the upper waveform area in Figure 4-70.

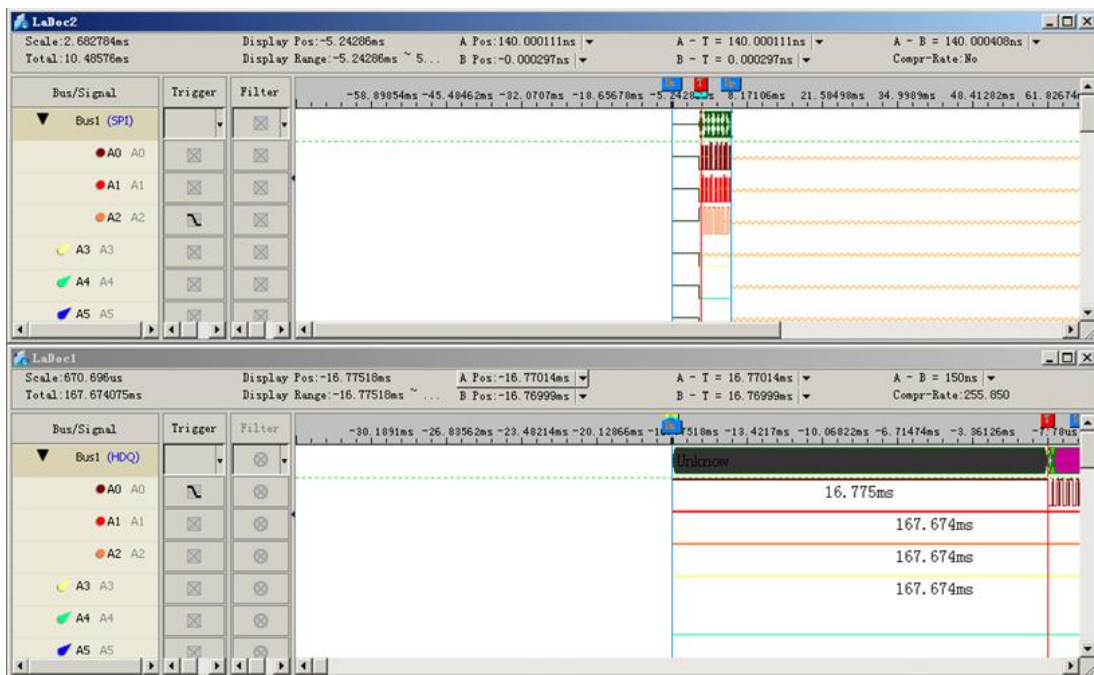

Figure 4-70 Files Comparison example



The Files Comparison function is free for users who buy the LAP-C162000, LAP-C321000 or LAP-C322000 models. Users who buy the LAP-C16032, LAP-C16064, LAP-C16128 and LAP-C32128 models can chose to purchase the function separately.



We provide an SDK that let's user customize the interface of the Files Comparison.

4.39. Filter

Filter out dips or pulses in signals.

4.39.1. Bus Width Filter

The Bus Width Filter is used to smooth out signals by filtering out pulses of a certain maximum length. Figure 4-71 and Figure 4-72 below show an example: After activating a 5 ns filter, the 0x1 data is filtered away.



The unit of the filter is the same as the Trace Information. If Trace Information shows sample points, the bus width filter is also measured in sample points, and likewise for time etc.

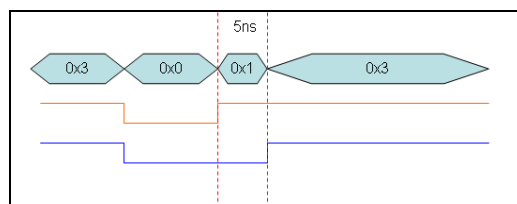

Figure 4-71 Bus Width Filter example – Before applying filter

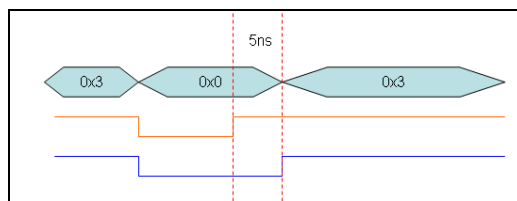

Figure 4-72 Bus Width Filter example – After applying filter



4.39.2. Noise Filter

The Noise Filter is used to filter out short-lasting signal pulses or dips that the user considers noise; see the dialog box in Figure 4-73. The user can choose just how short pulses/dips in the signal of any channel have to be to be filtered out. Lengths are measured in sample points.

In the example from Figure 4-74 and Figure 4-75, note how only channel 3 in yellow remains as before since the signals of channels A0-A2 all are pulses that fluctuate at 4 clocks or less.



Select “None” in the Noise filter dialog box to restore the waveform.



Figure 4-73 Noise Filter dialog box

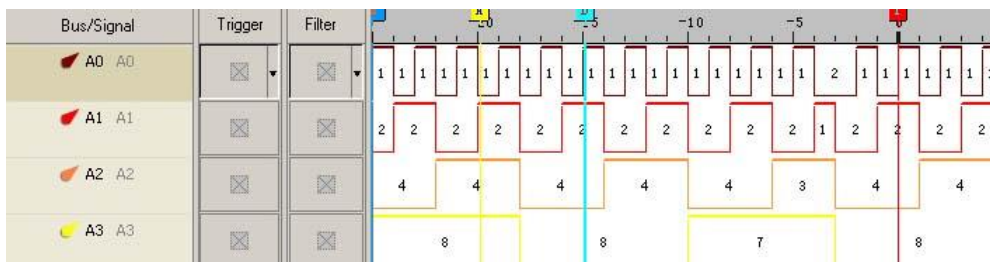

Figure 4-74 Noise filter example / Before applying 5 clock filter

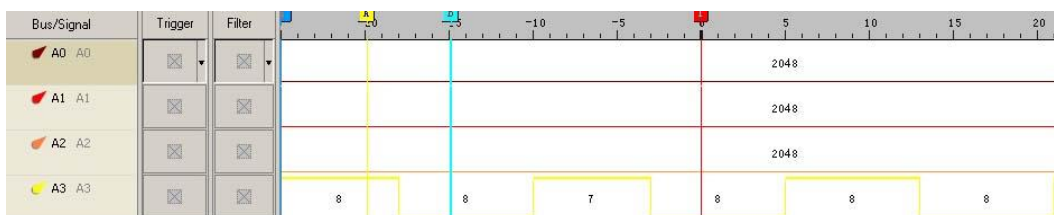

Figure 4-75 Noise filter example / After applying 5 clock filter



4.40. Image Decode

The Image Decode function is specially designed for display type protocols such as CMOS Image, 7-SEGMENT LED, LCD12864, LCD1602 etc. Captured data that are decoded with one of the supported protocols are decoded and displayed as the original picture. This makes for a painless and straightforward verification of the data being correct or not. See Figure 4-76 for an example of the function's output.

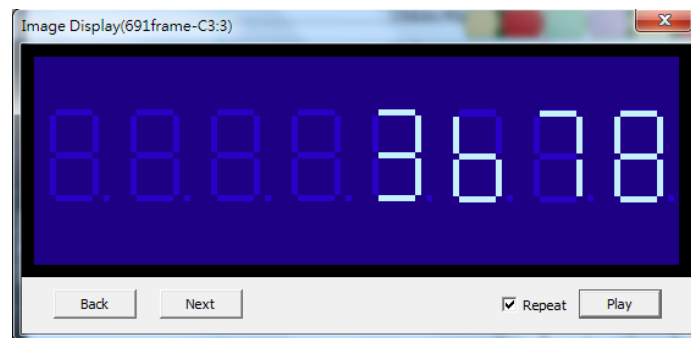

Figure 4-76 Image Decode for 7-Segment LED protocol

The Image Decode function supports the following protocols:

- 7-Segment LED
- CCIR
- CMOS Image
- DM114/115
- DMX512
- LCD12864
- LCD1602
- LED Pitch Array
- LG4572
- CCIR601



It's necessary to focus on the correct bus for the Image Decode function to be unlocked.

4.41. Numeric Base/Encoding

Users can choose among seven types of number systems and encodings for the



displayed bus data; see Table 4:29. Hexadecimal is the default format.

Numeric base/Encoding	Description
Binary	Data are shown using the binary number system.
Decimal	Data are shown using the decimal number system.
Decimal (Signed)	Data are shown using the signed decimal number system; one bit (the first on the left) is used to specify the sign.
Hexadecimal	Data are shown using the hexadecimal number system.
ASCII	Data are encoded as ASCII characters; this only works for buses that comprise at least seven signals.
Gray Code	Data are encoded as Gray code.
Complement	Data are encoded as complements.

Table 4:29 Available data formats

4.42. Signal Activity

Signal Activity offers the user real-time views of what the probes are seeing. Two modes are available; Real-time Frequencies and Signal Statuses. By means of these functions the LAP-C monitors signal frequencies and states, thus assuming the function of a frequency counter and that of a logic pen.

4.42.1. Real-Time Frequencies

Real-time frequencies of all channels as measured by the probes are shown; see Figure 4-77. The frequencies are updated twice per second.

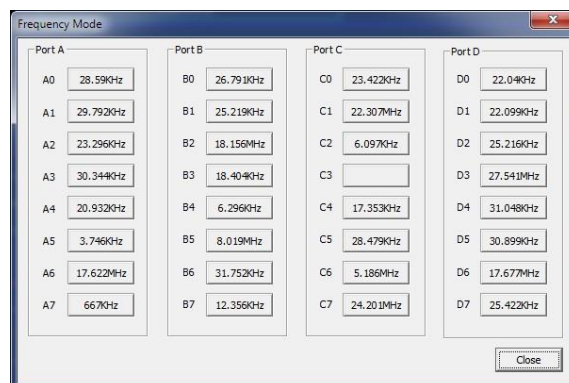

Figure 4-77 Real-Time Frequencies window



4.42.2. Signal Statuses

The Signal Statuses window shows another view of the probe activity; traffic lights indicate if a channel's signal is High (green light), Low (red) or transitioning (yellow); see Figure 4-78.

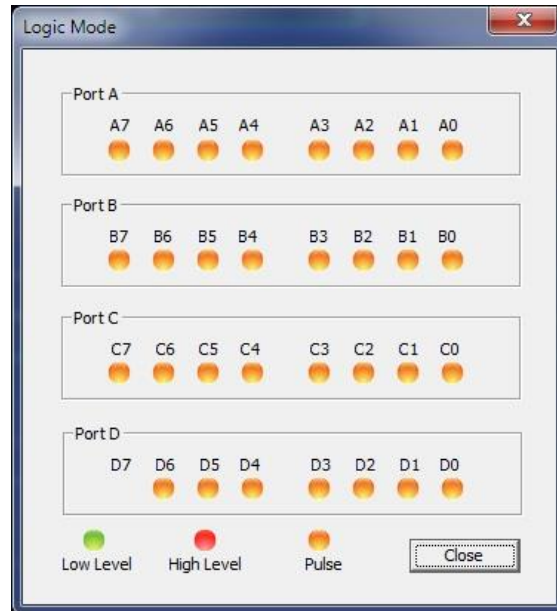

Figure 4-78 Signal Statuses window



View

4.43. Menu Layout

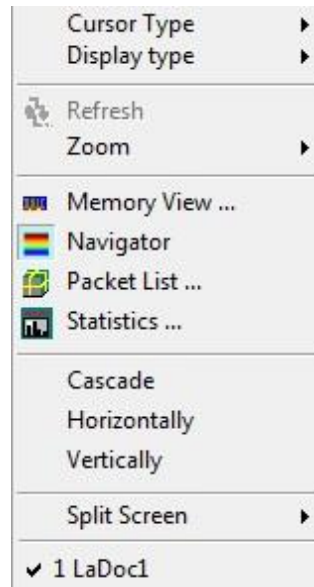

Figure 4-79 Acquisition drop-down menu

4.44. Cursor type

The user can choose between three cursor types.

4.44.1. Hand

In Hand mode, the left mouse button is used for panning; click and hold the left mouse button to move left and right in the waveform area. To move a bar, left click on the bar name and drag sideways. Left/right movement in the waveform is also achieved with the mouse wheel.

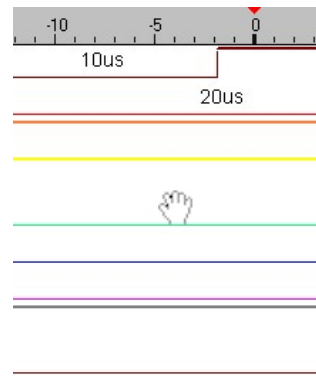

Figure 4-80 Hand mode - Press and hold the left key to navigate.

Hot Key: H

4.44.2. Normal

Use this mode to select objects, move bars, use the scroll bars etc. Left/right movement in the waveform is also achieved with the mouse wheel.

4.44.3. Zoom

In Zoom mode, form squares by pressing the left mouse button and dragging downwards/leftwards to zoom in. The area covered by the square will be amplified to occupy the entire waveform area. In other words, form small squares to zoom in quickly. Zooming out is achieved by doing the opposite; drag squares upwards/rightwards.

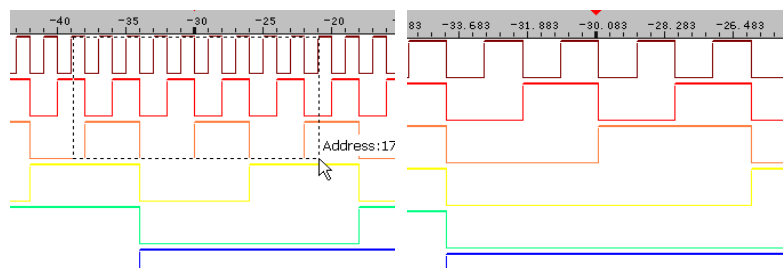

Figure 4-81 Zoom In movement.

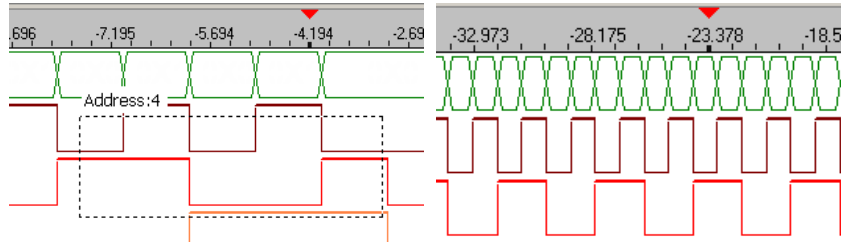

Figure 4-82 Zoom Out movement.

4.45. Display type

The menus that appear when right-clicking in the interface are found in chapter 3.1.2.

4.45.1. State list

State List is a numeric view of the samples. As an alternative to the waveform traces, the State List shows all samples as digits. If the logic state of a signal is low then “0” is shown and if it is high then “1” is shown. Unknown states are shown as “U”. Each column shows the samples of one channel and the leftmost column shows the sampling time. The State List view is shown in Figure 4-83.

Address	A0	A1	A2	A3	A4	A5	A6	A7	B0	B1	B2	B3	B4	B5	B6	B7
-22	0	0	1	1	0	1	1	1	0	0	0	0	0	0	0	0
-21	1	0	1	1	0	1	1	1	0	0	0	0	0	0	0	0
-20	0	1	1	1	0	1	1	1	0	0	0	0	0	0	0	0
-19	1	1	1	1	0	1	1	1	0	0	0	0	0	0	0	0
-18	0	0	0	0	1	1	1	1	0	0	0	0	0	0	0	0
-17	1	0	0	0	1	1	1	1	0	0	0	0	0	0	0	0
-16	0	1	0	0	1	1	1	1	0	0	0	0	0	0	0	0
-15	1	1	0	0	1	1	1	1	0	0	0	0	0	0	0	0
-14	0	0	1	0	1	1	1	1	0	0	0	0	0	0	0	0
-13	1	0	1	0	1	1	1	1	0	0	0	0	0	0	0	0
-12	0	1	1	0	1	1	1	1	0	0	0	0	0	0	0	0
-11	1	1	1	0	1	1	1	1	0	0	0	0	0	0	0	0
-10	0	0	0	1	1	1	1	1	0	0	0	0	0	0	0	0
-9	1	0	0	1	1	1	1	1	0	0	0	0	0	0	0	0
-8	0	1	0	1	1	1	1	1	0	0	0	0	0	0	0	0
-7	1	1	0	1	1	1	1	1	0	0	0	0	0	0	0	0
-6	0	0	1	1	1	1	1	1	0	0	0	0	0	0	0	0
-5	1	0	1	1	1	1	1	1	0	0	0	0	0	0	0	0
-4	0	1	1	1	1	1	1	1	0	0	0	0	0	0	0	0
-3	0	0	0	0	0	0	0	0	0	0	0	0	0	0	0	0
-2	1	0	0	0	0	0	0	0	0	0	0	0	0	0	0	0
-1	0	1	0	0	0	0	0	0	0	0	0	0	0	0	0	0
0	1	1	0	0	0	0	0	0	0	0	0	0	0	0	0	0
1	0	0	1	0	0	0	0	0	0	0	0	0	0	0	0	0
2	1	0	1	0	0	0	0	0	0	0	0	0	0	0	0	0

Figure 4-83 State List display

Note that there are three main presentations of the samples in the State List. One option is to show all samples. Alternatively, the user can select to display only those samples that include at least one change of state or in data. Table 4:30 shows an



example of how this works: Samples #1, #2 and #3 are shown if the user views all samples. If the user chooses to show changes in state only then Sample #2 will be hidden, as all channel states are identical to those of sample #1. The purpose of showing samples with changes in state only is to facilitate observation by reducing the quantity of displayed data. Likewise, the user can choose to only show samples where there has been a change in the data; see an example of this in Figure 4-84.



Right-click in the number area and choose “Show changes in state only” or “Show changes in data only” to hide consecutive, equal samples. See the right-click menu in Figure 3-8.



None of these view modes will delete samples, only hide them.

Timestamp		ch. A1	ch. A2	ch. A3	ch. A4
0 ns	(sample #1)	1	1	1	1
5 ns	(sample #2)	1	1	1	1
10 ns	(sample #3)	1	0	1	1

Table 4:30 State List example; change of channel state

Address	BUS0	A0	A1	A2	A3	A4	A5	A6	A7	A8	A9	A10	A11	A12	A13	A14	A15	B0
0	-3262 ~ -3263	Unknown	1	1	0	0	0	0	0	0	0	0	0	0	0	0	0	0
	-3262 ~ -225	Unknown	1	1	0	0	0	0	0	0	0	0	0	0	0	0	0	0
	-224 ~ 99	Start	0	1	0	0	0	0	0	0	0	0	0	0	0	0	0	0
	100 ~ 2323	Address:0	1	1	0	0	0	0	0	0	0	0	0	0	0	0	0	0
	2324 ~ 2635	Write	0	1	0	0	0	0	0	0	0	0	0	0	0	0	0	0
	2636 ~ 2960	A-ACK	0	1	0	0	0	0	0	0	0	0	0	0	0	0	0	0
	2961 ~ 5495	Data:0X00	0	1	0	0	0	0	0	0	0	0	0	0	0	0	0	0
	5496 ~ 5820	D-ACK	0	1	0	0	0	0	0	0	0	0	0	0	0	0	0	0
	5821 ~ 8354	Data:0X7F	0	1	0	0	0	0	0	0	0	0	0	0	0	0	0	0
	8355 ~ 8680	D-ACK	0	1	0	0	0	0	0	0	0	0	0	0	0	0	0	0
	8681 ~ 11213	Data:0X89	1	1	0	0	0	0	0	0	0	0	0	0	0	0	0	0
	11214 ~ 11539	D-ACK	0	1	0	0	0	0	0	0	0	0	0	0	0	0	0	0
	11540 ~ 14074	Data:0XA	1	1	0	0	0	0	0	0	0	0	0	0	0	0	0	0
	14075 ~ 14398	D-ACK	0	1	0	0	0	0	0	0	0	0	0	0	0	0	0	0
	14399 ~ 16934	Data:0XC	1	1	0	0	0	0	0	0	0	0	0	0	0	0	0	0
	16935 ~ 17259	D-ACK	0	1	0	0	0	0	0	0	0	0	0	0	0	0	0	0
	17260 ~ 19794	Data:0XE	1	1	0	0	0	0	0	0	0	0	0	0	0	0	0	0
	19795 ~ 20199	D-ACK	0	1	0	0	0	0	0	0	0	0	0	0	0	0	0	0
	20200 ~ 29505	Stop	1	1	0	0	0	0	0	0	0	0	0	0	0	0	0	0

Figure 4-84 Show changes in data only example (I2C)



Figure 4-84 shows an example of the “Show changes in data only” function. Had the function not been active there would have been tens of thousands of lines (one per sample) instead of twenty-something.



4.45.2. Waveform

In Waveform view, the state of each channel is shown as a trace that changes between high and low depending on the state of the signal. This is the default view mode.

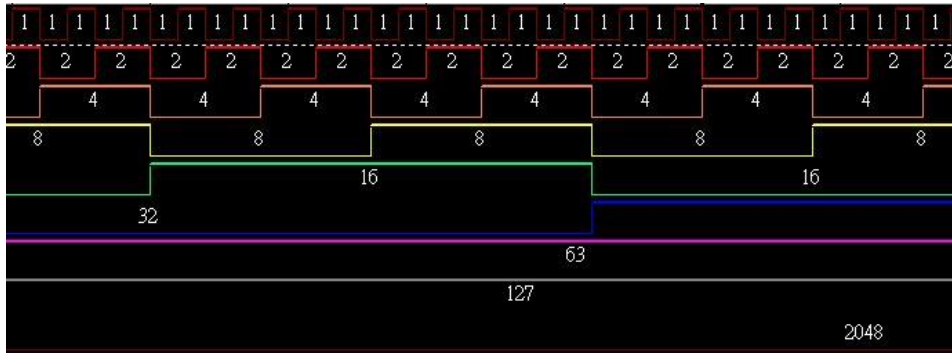

Figure 4-85 Waveform display



An unknown signal waveform is displayed as a mid-level (between high and low in terms of height), blue, constant trace.

4.46. Refresh

Refresh tells the LAP-C to re-decode the acquired data between the Ds and Dp bars. This can be of interest if the Analytic Range (see chapter 4.33) has been changed.



Analytic Range must be activated for this function to be available.

4.47. Zoom

Zoom In and Out can be accomplished in the following 3 different ways:

- Use the left mouse button to zoom in and out by click and dragging squares with the pointer.
- Select the desired zoom level from the zoom drop-down list in the Toolbar
- Press F8 to zoom out and F9 to zoom in.



4.47.1. In

Zoom in on the waveform.

4.47.2. Out

Zoom out of the waveform.

4.47.3. Fit to Screen

Show all data between Ds and Dp in the waveform view area. See Figure 4-86 below.

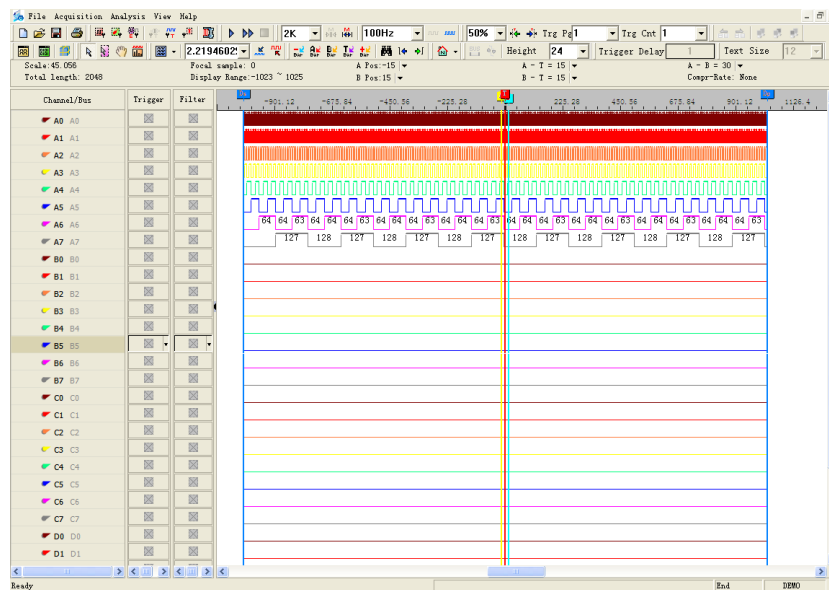

Figure 4-86 Fit to screen – Zoom to fit all data in one window

4.47.4. Previous

Undo the last zoom. In other words; go back to the previous zoom level.

4.48. Memory view

Memory View lets users see what the memory looks like after the signals have been transmitted. By decomposing the packets into basic elements, the relationship between data and addresses in a protocol is clarified. The Memory View window is



located in the lower part of the user interface.

Concretely, the Memory View window consist of tables that show which data have been read from and written to which address in the memory. Write data are displayed in red; Read in blue. See an example in Figure 4-87.

Two view modes can be accessed by right-clicking in the table area: Compact (default) and Full. The Compact Mode saves space as the information is presented in a matrix form; addresses are found by adding the column number/letter to the end of the row name, and the data located at that address is read directly from the intersection of the row/column.

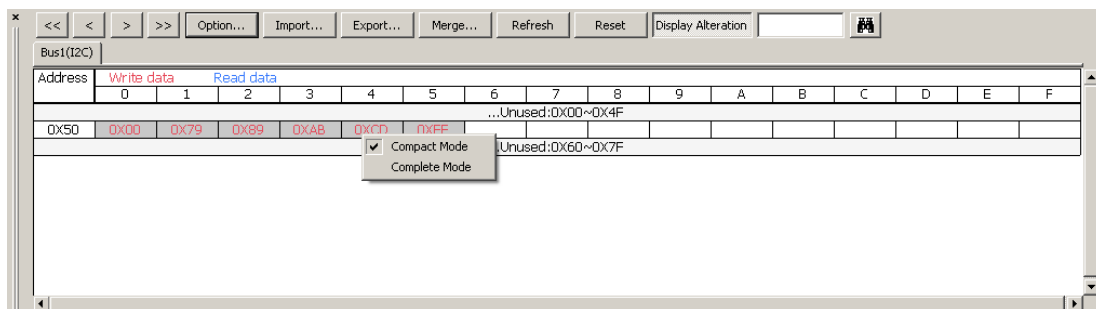

Figure 4-87 I2C Memory View / Compact Mode

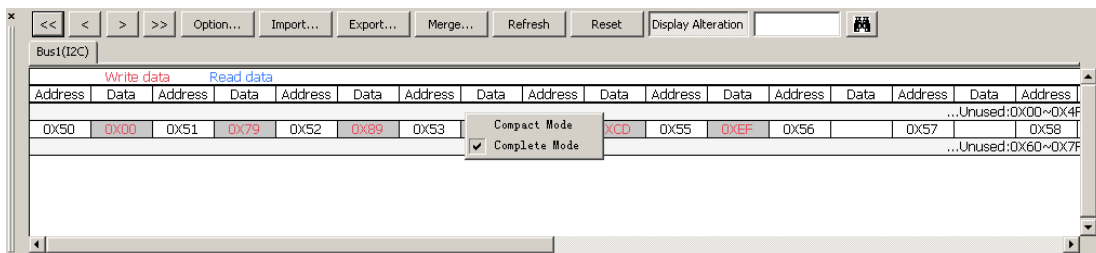

Figure 4-88 I2C Memory View / Complete Mode

Item	Description
	Navigation buttons: Use these to move between packets. The packet in focus will be in the middle of the waveform area and marked by the so-called Packet Location (A-bar by default). The packet data will be displayed in the Memory View window.
	Options; see the dialog box in Figure 4-89 below.









	Import a formerly exported Memory View file to analyze the data.
	Export the Memory View in .txt or .csv format.
	Merge two files. The File to Merge content is copied to the Object File, and the Object File is overwritten.
	Refresh the window to display new bus data.
	Delete all data in the Memory View window.
	The last written (read) data will be shown in the cells as red (blue) text on white background. If an address has been involved in more than one operation, the cell background color will be grey.
	Find: Input an address to look it up, shift the view to focus on it, and highlight it with a blue frame.

Table 4:31 Memory View description

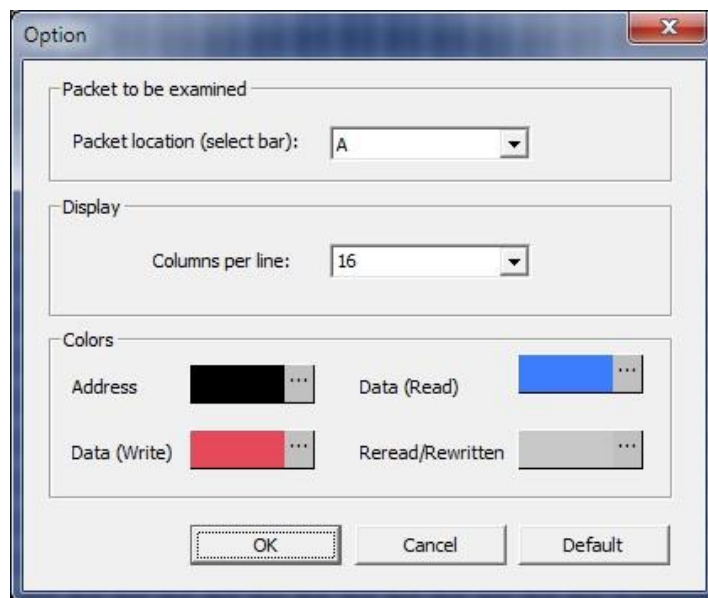

Figure 4-89 Memory View Options dialog box

Item	Description
Packet to be	The Memory View will analyze the packet that is located under the



examined	selected bar; the A-bar is selected by default. Note that the Ds, Dp and T-bars cannot be chosen.
Display	Choose how many cells to display per line. 4-100 is the permitted range; 16 is default.
Colors	Change the color settings. The default colors are: Address=black; Data (Read)=blue; Data (Write)=red; Error=gray.

Table 4:32 Memory View Options dialog box description

4.49. Navigator

The Navigator is a condensed form of the main waveform that is always zoomed to fit the entire capture. It facilitates waveform navigation by providing an overview of the entire acquisition and a tool for quick movement between distant parts of the acquisition. The Navigator is synchronized with the main waveform so users can shift the waveform focus from one part of the acquisition to another simply by clicking somewhere in the Navigator window.

The Navigator is shown under the waveform area as shown in Figure 4-90. Four signals are shown at a time; go down using the right scroll-bar to focus on other channels than the default A0-A3. A light blue frame (barely discernible around the yellow A-bar in Figure 4-90) in the Navigator indicates which part of the waveform is in focus. This frame naturally changes size when zooming, as it is inversely proportional to the zoom level.

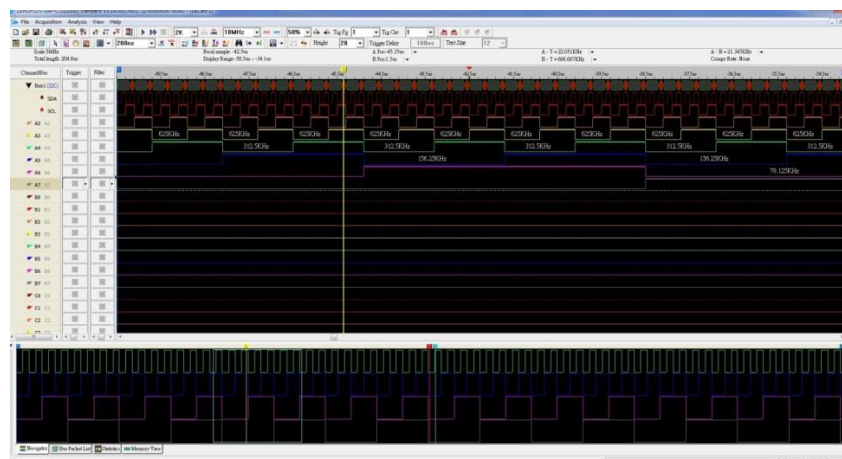

Figure 4-90 Navigator window shown under the waveform



4.50. Packet List

The Packet List shows all acquired packets in their decomposed form. By presenting the packets in list form, the Packet List facilitates observation and analysis of all packets and their relation. Note that a protocol decoder must be applied to the signals for the packets to be decomposed. The Packet List is located below the waveform area. See an example of the Packet List for an I2C protocol in Figure 4-91. Notice how the packets are sorted according to the TimeStamp.



If a packet in the Packet List is double-clicked, the waveform display shifts focus to the location of that packet.

Packet #	Name	TimeStamp	ADDRESS	Write	A-ACK	DATA	D-ACK	DATA	D-ACK	DATA	D-ACK	DATA	D-ACK		
1	Bus1(I2C)	-1us	50	Write	A-ACK	00	D-ACK	75	D-ACK	01	D-ACK	23	D-ACK	45	D-ACK
						DATA	D-ACK								
						67	D-ACK								
2	Bus1(I2C)	10.2064ms	50	Write	A-ACK	00	D-ACK	75	D-ACK						
3	Bus1(I2C)	10.2982ms	50	Read	A-ACK	01	D-NACK	DATA NACK							
4	Bus1(I2C)	10.3554ms	50	Read	A-ACK	23	D-ACK	45	D-ACK	67	D-NACK	DATA NACK			
5	Bus1(I2C)	20.477ms	50	Write	A-ACK	00	D-ACK	79	D-ACK	89	D-ACK	AB	D-ACK	CD	D-ACK
						DATA	D-ACK								
						EF	D-ACK								

Figure 4-91 Packet List example showing an I2C protocol

Item	Description
Menu Bar	
Settings	Open the Packet List Settings dialog box; see Figure 4-92.
Refresh	Refresh the content.
Export	Export the packet list as .txt or .csv file; see chapter 4.9.1.
Sync Parameters	Synchronize the Packet List with the waveform; see Figure 4-95.
Display Area	
Packet#	Packet# shows the order of the packets.
Name	The bus name.
Time Stamp	The packet start point.
Data	The data in the packet.

Table 4:33 Packet List description

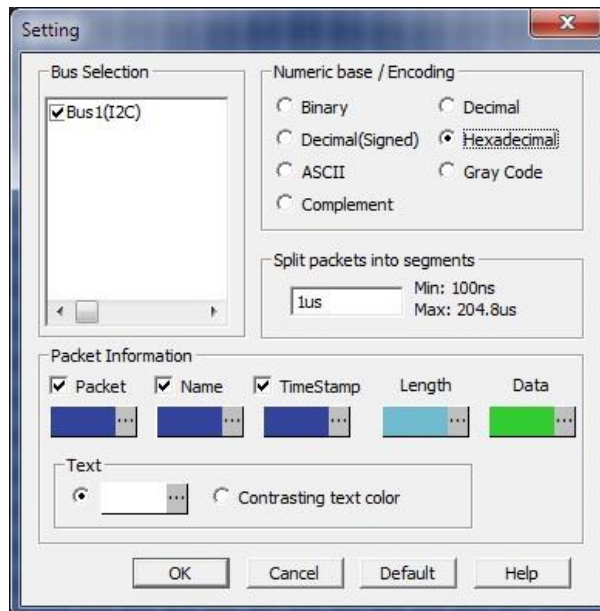
**Figure 4-92 Packet List Settings dialog box**

Item	Description
Bus Selection	Select which buses to display.
Numeric Base/Encoding	Choose how data should be displayed; see chapter 4.41.
Packet Length	This setting concerns packets that don't follow a specific protocol. Long segments of data can be divided into segments for presentation/organization purposes. See Figure 4-93.
Packet Information	Select the items to be displayed and their colors.
Colors	
Text	Change the text color; by default it's white.
Contrasting Colors	Automatically select text colors that contrast their backgrounds.

Table 4:34 Packet List Settings description

Figure 4-93 shows an example of how the Packet Length setting can be used to partition a large amount of data into a number of different packets. This function can be used useful for data that don't follow a specific protocol.

Packet #	Name	TimeStamp	Data	Data	Data	Data	Data	Data	Data	Data	Data	Data	Length
1	Bus1(Bus)	-10.23s	0	1	2	3	4	5	6	7	0	1	100ms
2	Bus1(Bus)	-10.13s	2	3	4	5	6	7	0	1	2	3	100ms
3	Bus1(Bus)	-10.03s	4	5	6	7	0	1	2	3	4	5	100ms
4	Bus1(Bus)	-9.93s	6	7	0	1	2	3	4	5	6	7	100ms
Packet #	Name	TimeStamp	Data	Data	Data	Data	Data	Data	Data	Data	Data	Data	Length

Figure 4-93 Packet Length example

The Synchronize Navigation function makes it easier to find data by synchronizing what is shown in the Packet List with the waveform area. Figure 4-95 shows an example of how the synchronization works.

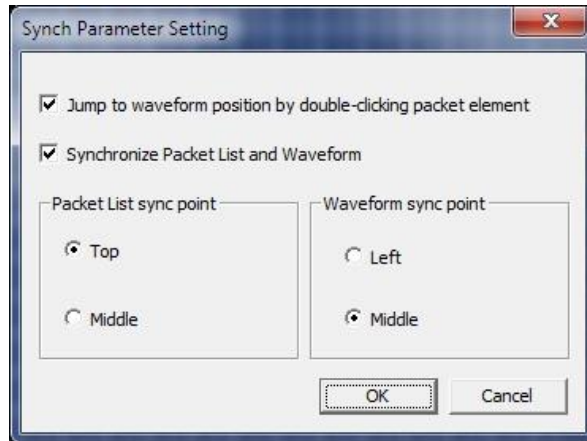

Figure 4-94 Packet List Settings / Synchronize Navigation dialog box

Item	Description
Jump by double-clicking	When double-clicking a packet the waveform focus shifts to the location of that packet.
Sync Packet List and Waveform	Synchronization navigation between the Packet List and the waveform.
Packet List sync point	
Top	The top Packet List element is used as reference point for synchronization.
Middle	The middle of the Packet List is used as reference point for synchronization.
Waveform sync point	
Left	The left of the waveform is used as reference point for synchronization.
Middle	The waveform center is used as reference point for synchronization.

Table 4:35 Packet List Settings/Sync Navigation dialog box description

In the example below, notice the red frames and how the packet in focus in the waveform is also shown in the Packet List.

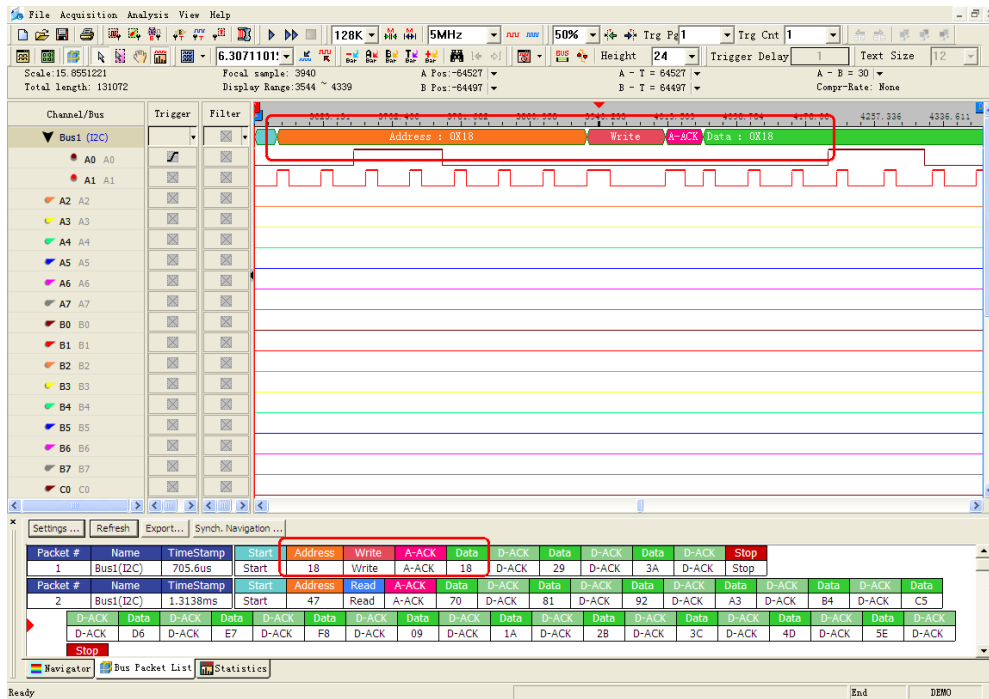

Figure 4-95 Synchronize Navigation example in red frames

4.51. Statistics

The Statistics window facilitates counting of signal transitions for each channel. Specifically, Full-, Positive- and Negative periods are all counted. Conditional counters are also available; these count all periods that are shorter or longer than a set of user defined conditions. Finally, it is also possible to adjust the Analytic Range, i.e. to only count activity within a certain range of the total acquisition. The Statistics window is shown in Figure 4-96; it is located below the waveform area.

Channel (p...)	Full Periods	Positive Per...	Negative P...	Full Periods...	Positive Per...	Negative P...	Start Position	End Position	Waveform Data (Hex)
SDA	1020	1020	1020	0	0	0	Ds	Dp	
SCL	514	514	514	0	0	0	Ds	Dp	
A2	257	257	257	0	0	0	Ds	Dp	
A3	128	128	129	0	0	0	Ds	Dp	
A4	64	64	65	0	0	0	Ds	Dp	
A5	32	32	33	0	0	0	Ds	Dp	
A6	16	16	17	0	0	0	Ds	Dp	
A7	8	8	9	0	0	0	Ds	Dp	
B0	0	0	1	0	0	0	Ds	Dp	
B1	0	0	1	0	0	0	Ds	Dp	
B2	0	0	1	0	0	0	Ds	Dp	
B3	0	0	1	0	0	0	Ds	Dp	
B4	0	0	1	0	0	0	Ds	Dp	

Figure 4-96 Statistics window

Item	Description
Channel Selection	Select channels to be included; see Figure 4-97.
Customize	Decide which counters to show; see Figure 4-98.
Filter	Only count periods that fit the filter conditions; see Figure 4-99.
Highlight Signals	Mark channels that don't fit user-defined conditions in red; see Figure 4-100 and Figure 4-101.
Refresh	Re-run the counters if there has been any change to the acquisition or the settings.
Count full periods only	Incomplete periods (don't have both a rising and a falling edge) will not be counted.

Table 4:36 Statistics window menu description

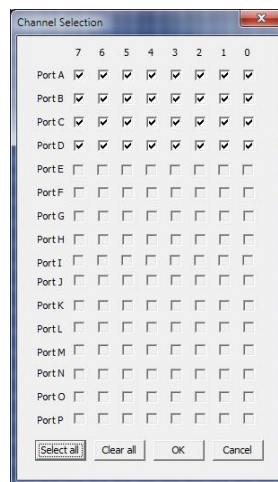

Figure 4-97 Statistics / Channel Selection – Select channels to include

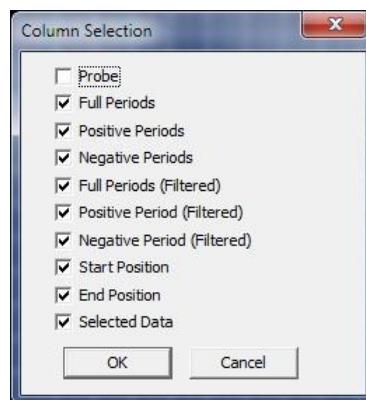

Figure 4-98 Statistics / Customize – Select which columns to display

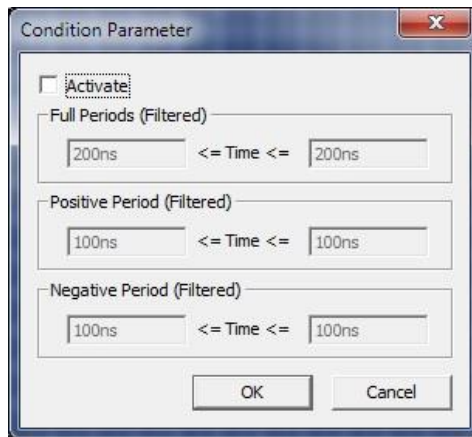

Figure 4-99 Statistics / Filter – Apply filter conditions

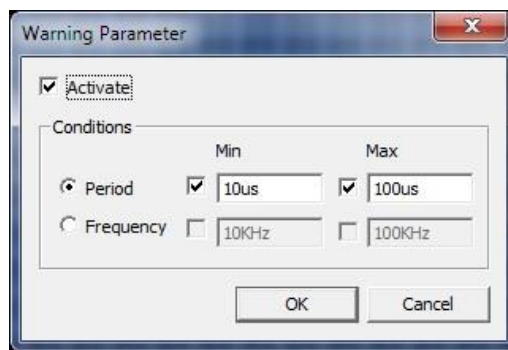

Figure 4-100 Statistics / Highlight Signals

Channel Selection	Customize	Filter	Highlight Signals	Refresh	<input type="checkbox"/> Count full periods only				
Channel (p...)	Full Periods	Positive Per...	Negative P...	Full Periods...	Positive Per...	Negative P...	Start Position	End Position	Waveform ...
SDA	1020	1020	1020	0	0	0	Ds	Dp	
SCL	514	514	514	0	0	0	Ds	Dp	
A2	257	257	257	0	0	0	Ds	Dp	
A3	128	128	129	0	0	0	Ds	Dp	
A4	64	64	65	0	0	0	Ds	Dp	
A5	32	32	33	0	0	0	Ds	Dp	
A6	16	16	17	0	0	0	Ds	Dp	
A7	8	8	9	0	0	0	Ds	Dp	
B0	0	0	1	0	0	0	Ds	Dp	
B1	0	0	1	0	0	0	Ds	Dp	
B2	0	0	1	0	0	0	Ds	Dp	
B3	0	0	1	0	0	0	Ds	Dp	

Figure 4-101 Statistics / Highlight Signals example

4.52. Arrange Windows

The windows showing the files (as Waveforms or as State Lists) can be moved around and arranged as detailed in the following subchapters.



4.52.1. Cascade

Arrange the open files in cascade style; all files are put in a single stack that has been fanned out so that the titles of each file appear.

4.52.2. Horizontally

Arrange the open files above each other.

4.52.3. Vertically

Arrange the open files in a side-by-side pattern.

4.53. Split Screen

If more than one screen is connected to the computer the software is running on, users can choose to show the software on either one of the screens or on both.

4.53.1. Show on All

Show the software on both screens. The waveform area is amplified to show a larger part of the traces.

4.53.2. Show on Primary

Show the software on what is defined as the primary screen.

4.53.3. Show on Secondary

Show the software on what is defined as the secondary screen.



4.54. (Open files)

A list comprising all currently open files is shown at the bottom of the View menu.

MSO

4.55. Menu Layout

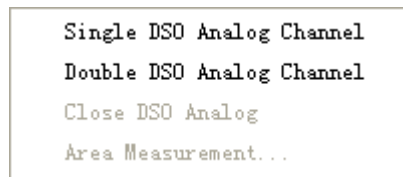

Figure 4-102 MSO drop-down menu

4.56. Single DSO Analog Channel

Single DSO Analog Channel, disable A0-A7 channels, enable the DSO CH1 channel to acquire analog signals.

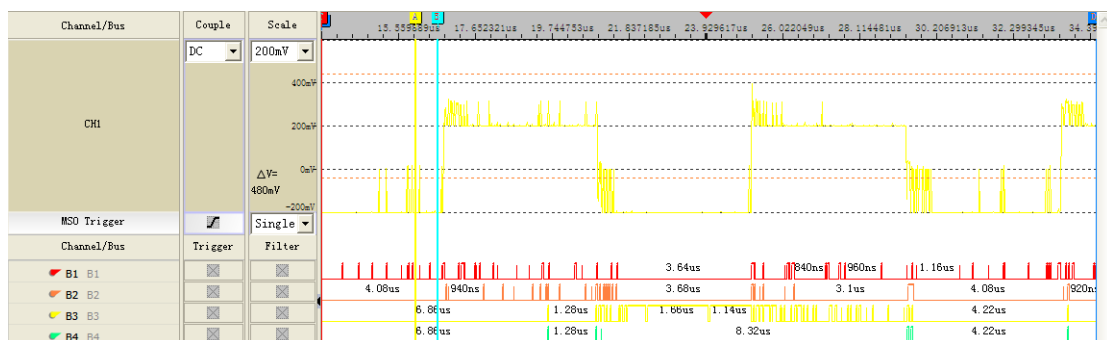

Figure 4-103 Single DSO Waveform Window



4.57. Double DSO Analog Channel

Double DSO Analog Channel, disable A0-B7 channels, enable the DSO CH1 and CH2 channels to acquire analog signals.

DSO analog channels are used in external sample rates with 2.5MHz、5MHz、10 MHz、25MHz、50MHz or 100MHz, acquisition depth with 2K, 16K or 32K.

MSO Trigger channel is used by the trigger channel for MSO.

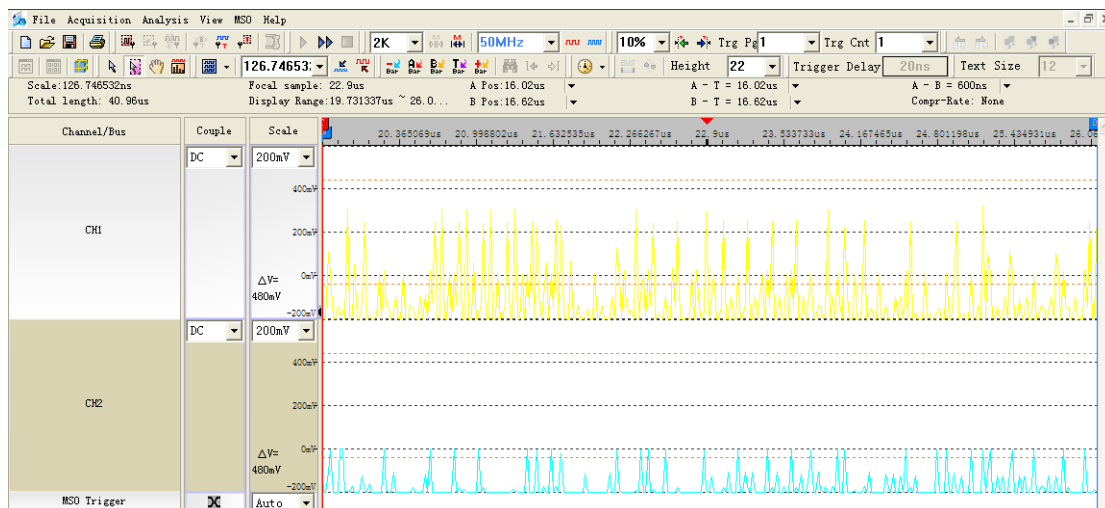

Figure 4-104 Double DSO Waveform Window

Couple: Select Input source for the channel, AC or DC(disable AC temporarily).

Scale: Set the scale for voltage per division, 5.00 V/div、2.00 V/div、1.00 V/div、500 mV/div、200 mV/div or 100 mV/div.

ΔV : Show the voltage difference of two removable cursors.

MSO Trigger: Set the trigger condition for DSO Analog Channels.

Auto: Auto trigger mode. Acquire analog waveform with the setting trigger condition repeatedly. If there is not waveform fit to trigger, wait some time and trigger automatically ignore the condition until press the stop button.

Normal: Normal trigger mode. Acquire analog waveform with the setting trigger condition repeatedly. If there is not waveform fit to trigger, wait until press the stop button.



Single: Single trigger mode. Acquire analog waveform one time. If there is not waveform fit to trigger, wait until press the stop button.

4.58. Close DSO Analog Channel

Close DSO analog channels and enable logic channels.

4.59. Area Measurement

Measure and display the data of DSO channels, such as Vmax, Vmin.

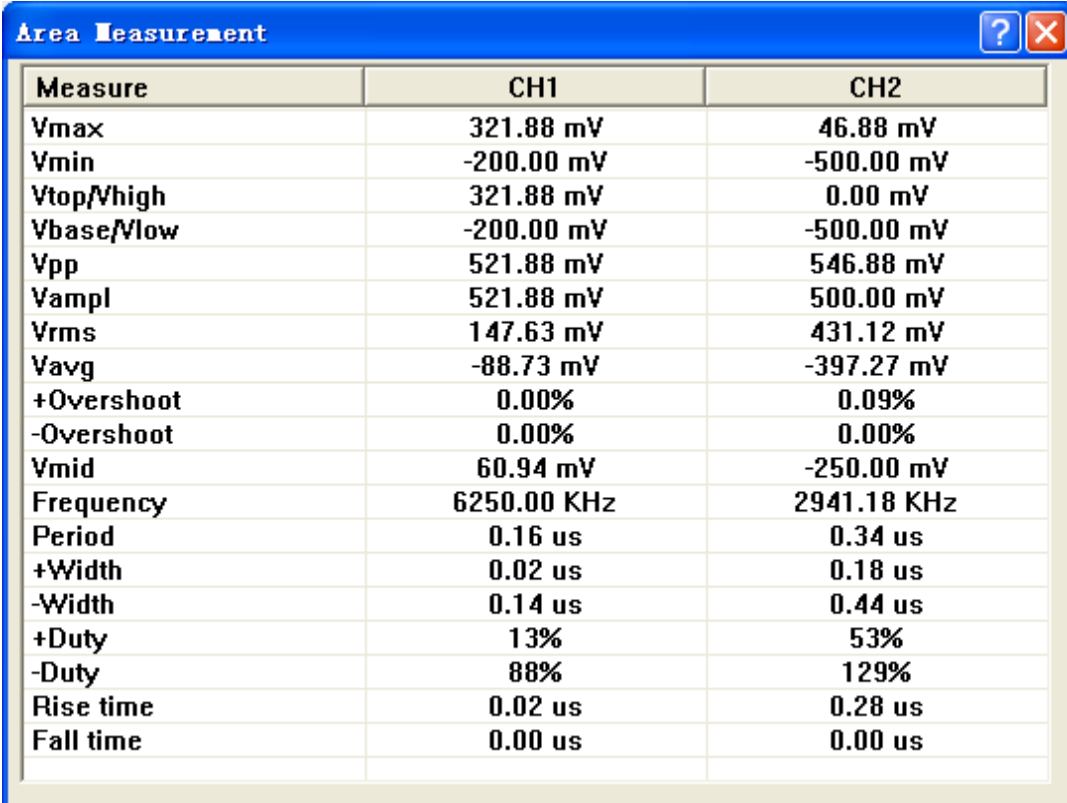

Measure	CH1	CH2
Vmax	321.88 mV	46.88 mV
Vmin	-200.00 mV	-500.00 mV
Vtop/Vhigh	321.88 mV	0.00 mV
Vbase/Vlow	-200.00 mV	-500.00 mV
Vpp	521.88 mV	546.88 mV
Vampl	521.88 mV	500.00 mV
Vrms	147.63 mV	431.12 mV
Vavg	-88.73 mV	-397.27 mV
+Overshoot	0.00%	0.09%
-Overshoot	0.00%	0.00%
Vmid	60.94 mV	-250.00 mV
Frequency	6250.00 KHz	2941.18 KHz
Period	0.16 us	0.34 us
+Width	0.02 us	0.18 us
-Width	0.14 us	0.44 us
+Duty	13%	53%
-Duty	88%	129%
Rise time	0.02 us	0.28 us
Fall time	0.00 us	0.00 us

Figure 4-105 MSO Area Measurement dialog

The parameters explain to follow table.

Measurement parameters	Description
------------------------	-------------

[Voltage parameters](#)



Vmax	Maximum voltage value
Vmin	Minimum voltage value
Vtop/Vhigh	Common points above midpoint
Vbase/Vlow	Common points below midpoint
Vpp	Peak to peak value
Vampl	Amplitude value
Vrms	Root mean square value
Vavg	Average value
+Overshoot	Positive overshoot
- Overshoot	Negative overshoot
Vmid	Middle value on waveform
Time Parameters	
Frequency	Frequency of waveform
Period	Time Period of waveform
+Width	Positive pulse width
-Width	Negative pulse width
+Duty	Positive duty cycle
-Duty	Negative duty cycle
Rise time	Waveform rise time
Fall time	Waveform fall time

Table 4:37 MSO Area Measurement dialog description

NOTE The parameter unit mV or V of the parameter single voltage of the voltage varies according to the vertical scale mV/div or V/div set.

4.60. DSO Module

Figure 4-105 and Figure 4-106 show the DSO Module from view and setting panel. All inputs and outputs are located to the left and right as visible in Figure 4-105. The right ports are DSO output ports connect to LAP-C, and the left ports are the DSO input ports connect to text ports.



Figure 4-106 DSO Module View

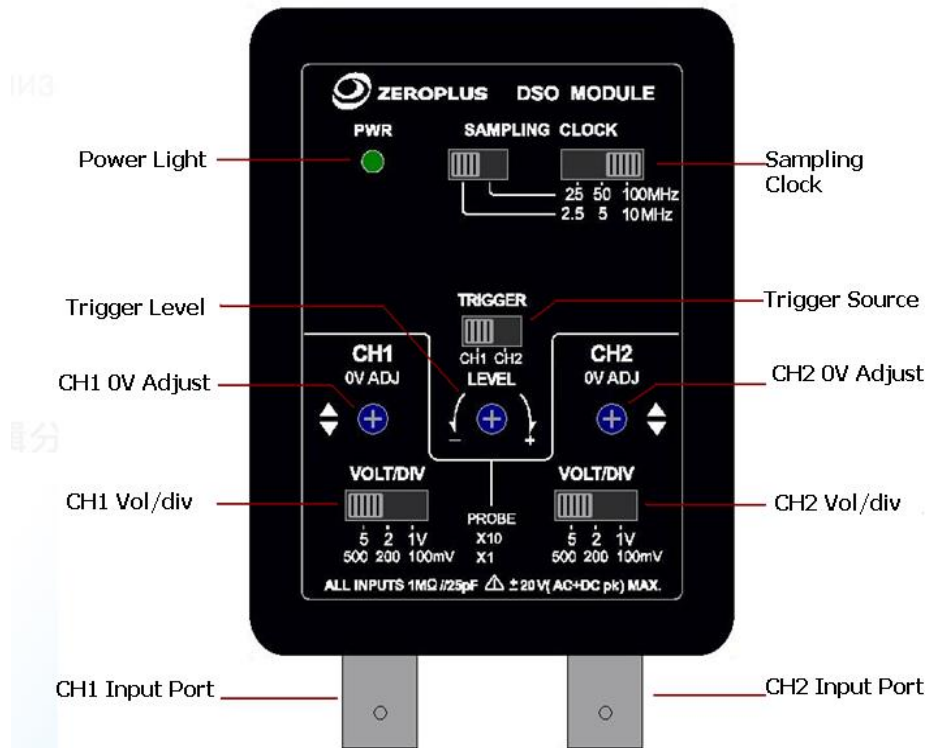

Figure 4-107 DSO Module Setting Panel

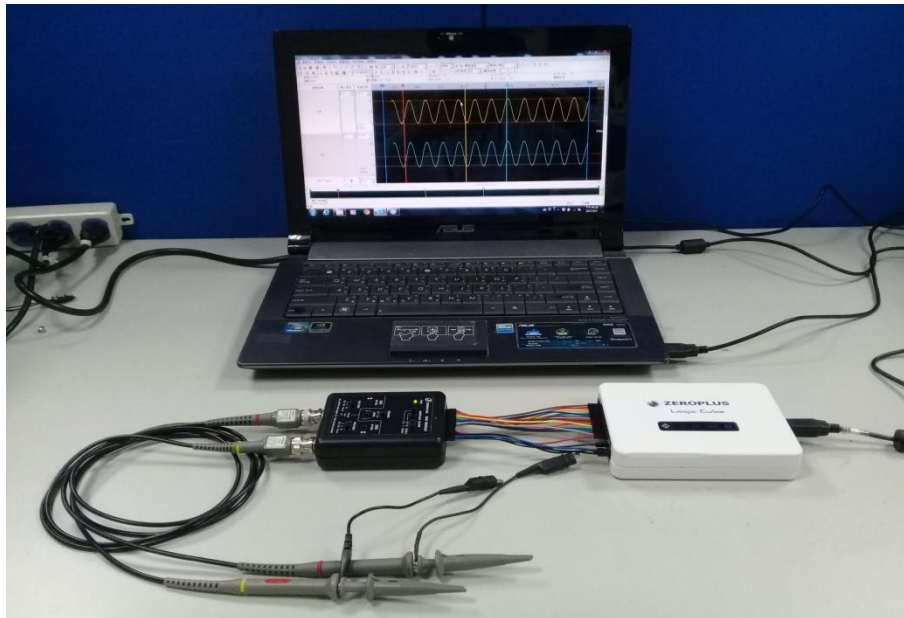

Figure 4-108 Connect with DSO Module

Specification parameters

Acquisition

Sampling	100M, 50M, 25M, 10M, 5M, 2.5M
----------	-------------------------------

ADCs	100MS/s 8 bits ADC x2
------	-----------------------

Record Length	32k, 16k, 8k / ch
---------------	-------------------

Vertical

Bandwidth	DC~20MHz
-----------	----------

Input Channels	2 (CH1/CH2)
----------------	-------------

Input Sensitivity	100mV, 200mV, 500mV/div at x1 probe 1V, 2V, 5V/div at x10 probe
-------------------	--

Input Coupling	DC
----------------	----

Input Impedance	1MΩ//25pF
-----------------	-----------

Max. Input Voltage	± 20V (DC+AC pk)
--------------------	------------------

Vertical Position	0V Adjustable
-------------------	---------------

DC Accuracy	± 3%
-------------	------

Trigger

Trigger Mode	Auto, Normal, Single
--------------	----------------------

Source	CH1, CH2, Logic channels from LAP-C
--------	-------------------------------------

Coupling	DC
----------	----

Slope	Rising, Falling
-------	-----------------

Trigger Level	Adjustable
---------------	------------

Measurement



Cursor Measurement	Time difference, Voltage difference
Auto Measurement	Frequency, Period, Max, Min, High, Low, Vpp, Vampl, Vrms, Mid, +Duty, -Duty, +Width, -Width, Rise time, Fall time, +Overshoot,-Overshoot, Vavg
Others	
Probe Comp.	2.5kHz, 3Vp-p, Square wave
Interface	A0~A7, B0~B7, Ext CLK, VDD, GND connect to LAP-C
Dimensions	145 x 70 x 25 mm
Weight	< 0.2kg

Table 4:38 MSO Area Measurement dialog description

Help

4.61. Menu Layout

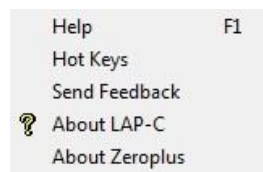

Figure 4-109 Help drop-down menu

4.62. Help

The Help file contains descriptions of the installation procedure, menus and functions, answers to FAQs etc. It has a search function that facilitate lookups.

Hot Key: F1

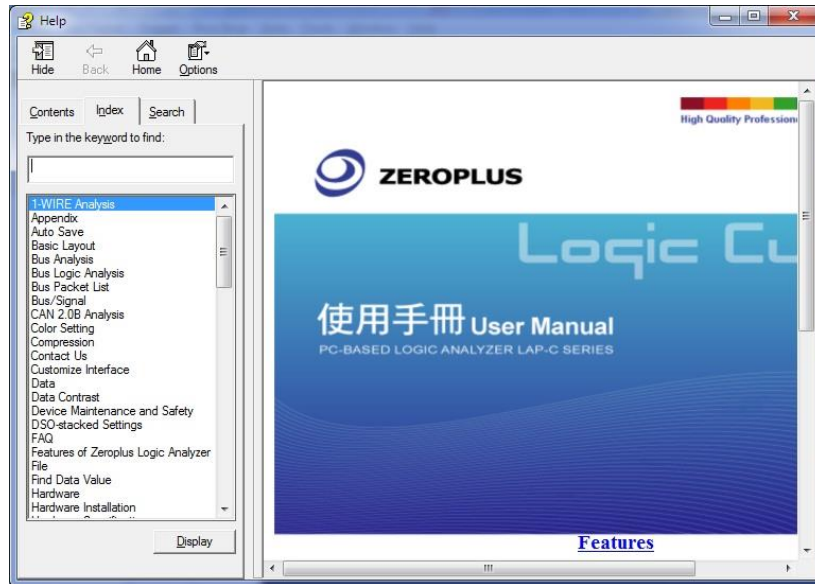

Figure 4-110 Help window

4.63. Hot Keys

Click to see a list of all Hot Keys combinations. Hot Keys are keyboard combinations that the user can press to execute an action or a function without having to open a menu or use the mouse. Some Hot Keys require only a single keystroke.

Users can customize the Hot Keys from the Settings menu. See chapter 4.12.5 for descriptions of the Settings / Hot Keys dialog box fields.

Hot Key	Description
A	Move the A-bar to the center of the waveform; select A-bar by the cursor.
B	Move the B-bar to the center of the waveform; select B-bar by the cursor.
T	Move the T-bar to the center of the waveform; select T-bar by the cursor.
E	Change the mouse pointer mode to Zoom
H	Change the mouse pointer mode to Hand.

Table 4:39 Hot Keys - Letters

Hot Key	Description
Ctrl + A	Reposition the A-bar to the center of the waveform.
Ctrl + B	Reposition the B-bar to the center of the waveform.
Ctrl + C	Open the Screen Capture dialog box.



Ctrl + E	Change pointer mode to Zoom.
Ctrl + F	Search for data or events.
Ctrl + G	Group selected signals into bus.
Ctrl + N	Create a new file.
Ctrl + O	Open a saved file.
Ctrl + P	Print an active file.
Ctrl + S	Save an active file with its current name, location and file format.
Ctrl + U	Ungroup signals from a bus.
Ctrl + Z	Undo last zoom.
Ctrl + Shift + E	Open the Export Waveform dialog box.

Table 4:40 Hot Keys - Combinations

Hot Key	Description
Page Down	Move one waveform window to the right.
Page Up	Move one waveform window to the left.
Home	Go to the front end of the waveform.
End	Go to the tail end of the waveform.
Up	Move upwards in the channel list/waveform area.
Down	Move downwards in the channel list/waveform area.
Left	Move to the left in the waveform area.
Right	Move to the right in the waveform area.
ESC	Release selected bars and return pointer mode to Normal.
Space	Change trigger condition when in the Trigger Column.

Table 4:41 Hot Keys - Control and navigation keys

Hot Key	Description
F1	Open Help.
F2	Decrease the acquisition rate.
F3	Increase the acquisition rate.
F5	Start acquisition.
F6	Start repeated acquisition.
F7	Stop the acquisition.
F8	Zoom out.
F9	Zoom in.
F10	Zoom to fit entire waveform in screen.
F11	Move forward to the prior variation waveform and center that location.



F12 Move forward to the next variation waveform and center that location.

Table 4:42 Hot Keys - Function keys

4.64. Send Feedback

The Send Feedback form can be used to contact our Technical Support for users who run into a problem. Users are requested to provide contact information and a description of the problem. Attachments can also be uploaded; see Figure 4-111.

The benefit of using the Send Feedback form to contact the Technical Support is that data and information is automatically added to the communication: file information, instrument model, acquisitions settings, system parameters etc. This information makes it easier for the support team to get to the root of the problem and therefore improves response times.

Users who prefer to contact our Technical Support team by means of regular email should use the following address: support@zeroplus.com.tw

Figure 4-111 Send Feedback form

Item	Description
------	-------------



Company/School	Name of the senders company / institution.
Sender	Name of the sender.
User Email	Sender's email address.
Phone	Sender's phone number.
Subject	Sender's brief description of the issue.
Attachment	Relevant files, graphs etc can be attached to the form.
Content	Elaborate a written description of the issue.
Parameters	LAP-C automatically adds information about the model, acquisition settings etc. to the file to facilitate problem solving.

Table 4:43 Send Feedback form description

4.65. About LAP-C

The About LAP-C window shows the software version, modification history, the instrument model, serial number and so on; see Figure 4-112. This window is almost identical to the information window shown the first time the LAP-C is started.



Figure 4-112 About LAP-C information window



4.66. About ZeroPlus

The About ZeroPlus item on the menu takes the user to the ZeroPlus website; this is opened in a new tab in the default web browser. Among others, the latest version of the software and User Manual can be downloaded from our website. The web address is www.zeroplus.com.tw.





5. Contact Us

Please feel free to contact us if you have any doubts or question. We would like to hear from you.

Sales	
Email	sales@zeroplus.com.tw
Phone	+886-2-6620-2225 extension #221 or #311

Table 5:1 Contact info Sales Department

Technical Support	
Email	support@zeroplus.com.tw
Phone	+886-2-6620-2225 extension #374

Table 5:2 Contact info Technical Support